

Oil & Gas



Company Profile

HiFluid, located in Ji'nan, China, national high-tech enterprise, science and technology-based SME, has been focusing on providing safe, stable, intelligent, and customized solutions for advanced ultra-high-pressure fluid applications such as hydrogen compression, high-pressure testing, high-pressure processing (HPP), solid-electrolyte battery production etc. as well as pressure generation unit and control & transfer unit for standard ultra-high-pressure fluid systems since its establishment in 2019. Leveraging its core competencies in design, equipment, and quality assurance, the company is committed to helping customers minimize lifecycle operational costs through energy-saving technologies and extended maintenance intervals.

The company has achieved certifications for ISO 9001 Quality Management System, ISO 14001 Environmental Management System, and ISO 45001 Occupational Health and Safety Management System. We strive to differentiate ourselves from traditional suppliers by embodying the role of consultants and solution providers with our expertise and craftsmanship.

All greatness comes from a brave beginning.

Contents

■ Why Choose HiFluid	01
■ Product Portfolio	02
01 Wellhead Control Panel (WHCP)	02
02 Injection Systems	03
• Chemical Injection System	
• High-Pressure Gas Injection System	
03 Testing Systems	05
• Portable Hydrostatic Test System	
• Portable Gas Tightness Test System	
• Hydrostatic Test System	
• Gas Tightness Test System	
• Fatigue Pulse Test System	
• Deep-Sea Environment Simulation Test System	
04 High-Pressure Components	12
• Air Driven Liquid Pumps	
• Air Driven Gas Boosters	
• Electric Driven Gas Boosters	
• Hydraulically Driven Gas Boosters	
• Valves, Fittings & Tubing	

1 Integrated Customization



- As a specialist in customized and integrated solutions for the ultra-high-pressure fluid industry, HiFluid provides one-stop services covering design, manufacturing, factory testing, on-site installation, commissioning, and personnel training. This integrated approach effectively addresses system integration challenges.
- All high-pressure core components are independently developed by HiFluid, ensuring optimal matching between components and overall system performance, avoiding the “weakest-link effect” caused by mixing equipment from different brands, and ultimately saving customers time and engineering costs.

2 Safety and Reliability



- Safety and reliability form the baseline of effective risk control. From the earliest design stage, HiFluid incorporates multiple safety features such as pressure relief devices, overload protection, and safety interlocks, establishing multi-layered protection to minimize accident risks and safeguard personnel and equipment assets.
- All products fully comply with or exceed the most stringent international standards and certifications, including API, ISO, and CE, ensuring that every stage of design, manufacturing, and testing is governed by established standards with controlled risks.
- Prior to delivery, each product undergoes pressure proof testing and performance testing at levels well above its rated working pressure, ensuring reliable and safe operation and eliminating potential issues during on-site commissioning and operation.

3 Intelligent Monitoring



- HiFluid’s independently developed intelligent control platform serves as the core of the entire equipment control system, enabling one-touch start and stop, automated process control, and adaptive parameter adjustment. This significantly reduces reliance on manual intervention while ensuring standardized and stable production and testing conditions.
- The control system features advanced diagnostic and predictive maintenance capabilities, allowing potential faults to be anticipated through real-time data analysis, transforming passive maintenance into proactive prevention and becoming a key enabler of continuous operation and elimination of unplanned downtime.
- Real-time equipment data is seamlessly integrated with management platforms, providing data support for higher-level systems and enabling digitalized and transparent data management to support optimized decision-making.

4 Adaptability to Complex Operating Conditions



- In oil and gas wells, the pressurized transportation of mixed production fluids—comprising water, oil, and gas—requires equipment capable of reliably handling high pressure as well as complex two-phase or three-phase flow conditions.
- HiFluid’s independently developed boosters are specifically designed for pressurizing and transporting gas-liquid mixtures, with working media including mixed water, oil, and gas. Featuring strong contamination resistance and eliminating cavitation issues commonly encountered with conventional boosters, these solutions are particularly well suited for oil wells with high associated gas volumes and gas wells with high liquid production during drainage and production enhancement operations.

Application Scope

Applicable to valve operations at oil and gas wellheads and downhole locations equipped with hydraulic actuators. The system provides hydraulic opening/closing and basic protection functions for relevant valves based on site requirements, and is suitable for wellsite conditions requiring local or remote hydraulic operation.



- API 6A
- API 14A
- API 17D

Technical Parameters

Pressure Rating:	5,000psi, 10,000psi, 15,000psi, 20,000psi, 30,000psi	Controlled Devices:	SCSSV/MSSV/WSSV/SSV/ESP, etc.
Drive Type:	Manual / Pneumatic / Electric / Solar	Ambient Temperature:	-40°C ~ +70°C
Working Medium:	Hydraulic oil, etc.	Ingress Protection:	IP65
Electrical Control:	Conventional electrical control, etc.	Explosion-Proof Rating:	Exd II BT4 Gb

Functional Features

Flexible

- Power unit options can be selected according to site conditions, including electric, pneumatic, and manual types, to accommodate different power supply modes at wellsites.
- Key components within the control system utilize proven and widely adopted oil & gas industry components to enhance applicability under real operating conditions.
- The equipment enclosure adopts a sealed structure and corrosion-resistant stainless steel materials, making it suitable for offshore or high-humidity environments.

Reliable

- The system can perform sequential operation or step-by-step open/close control of surface and downhole valves equipped with hydraulic actuators in accordance with process logic requirements.
- Emergency shutdown logic triggered by fire conditions can be configured as required to meet wellsite safety management requirements.
- On-site executable Emergency Shutdown (ESD) functions can be configured as needed to enable rapid well shut-in actions.
- Optional pressure monitoring and abnormal condition response mechanisms can be configured to trigger protective actions when pipeline pressure deviates from preset limits.
- The system provides remote shutdown signal interfaces for emergency shutdown interlocking with control rooms such as DCS.

Safe

- Upon receiving over-limit concentration signals from external gas detection devices, the system can execute interlocked alarm and shutdown control.
- Process shutdown and recovery operations can be configured according to production requirements to accommodate different wellsite operating procedures.

Application Scope

The Chemical Injection System is used to deliver methanol, ethylene glycol, and other required chemical agents to oil and gas wellheads, Christmas trees, or surface process pipelines, meeting production requirements such as hydrate prevention, wax inhibition, scale control, corrosion protection, corrosion inhibition, and foam suppression.

The system is applicable to onshore wellsites, gathering and transportation pipelines, natural gas processing plants, and offshore platforms, and can be configured for metered injection or intermittent injection according to site requirements.

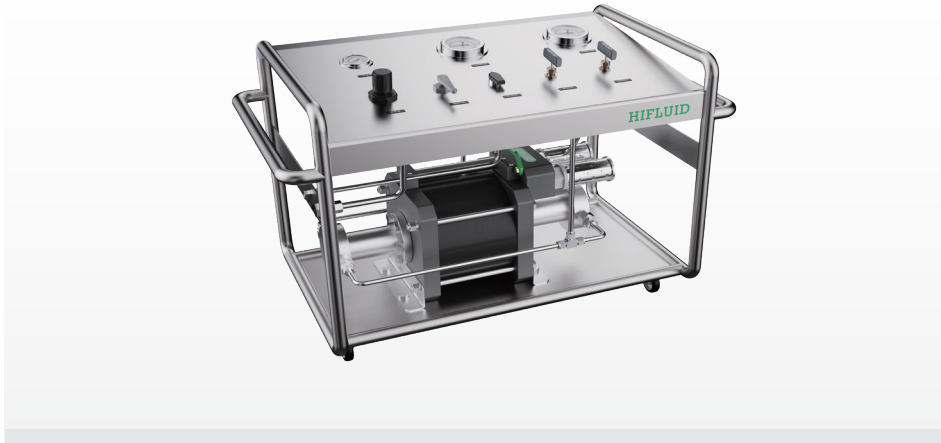

- API 6A
- API 14A
- API 17D

Technical Parameters

Pressure Rating:	10,000psi ~ 30,000psi	Ambient Temperature:	-40°C ~ +70°C
Drive Type:	Pneumatic / Electric	Structural Configuration:	Skid-mounted, Frame-mounted, Partially Enclosed
Working Medium: Methanol, Ethylene Glycol, and other site-specified chemical agents			

Functional Features

- Different drive options—including pneumatic, manual, or electric—can be configured based on injection pressure and media characteristics, making the system suitable for various operating conditions.
- Key wetted components are manufactured from corrosion-resistant materials to ensure compatibility with chemical agents.
- The system incorporates pressure stabilization, filtration, and backflow prevention designs to ensure stable and reliable injection.
- Structural configurations include skid-mounted, semi-enclosed, or frame-mounted designs, facilitating on-site installation and routine maintenance.
- Manual adjustment or simple control can be applied based on injection rate requirements, enabling continuous or intermittent injection modes.

Stable

Portable

Application Scope

The High-pressure Gas Injection System is a surface injection solution used to enhance oil and gas production and improve recovery efficiency. By pressurizing gaseous media on the surface and injecting it steadily into the wellbore or reservoir, the system helps maintain reservoir pressure, improve fluid flow characteristics, and enhance displacement efficiency, thereby increasing oil and gas output and overall development economics.

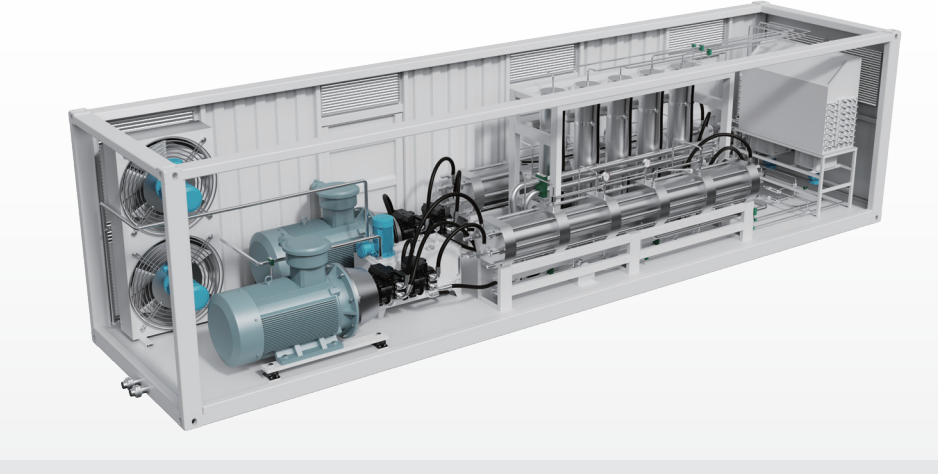

- SY/T 5323

Technical Parameters

Pressure Rating: 18,000psi	Ambient Temperature: -20°C ~ +55°C
Drive Type: Hydraulic, Electric	Structural Configuration: Skid-mounted, Containerized
Applicable Gases: Nitrogen, Air, Natural Gas, Helium, and other industrial gases	Typical Applications: High-pressure gas injection, gas tightness testing, valve testing, pressure holding, and related operations

Functional Features

High Pressure

- Provides stable and adjustable high-pressure gas output.
- Suitable for high-pressure gas injection and process operations.
- Pressure ratios can be configured according to requirements, enabling medium-, high-, and ultra-high-pressure gas output.

Robust Design

- The system can be equipped with pressure regulation, pressure stabilization, pressure holding, and venting functions, making it suitable for various testing and process procedures.
- Primary gas-contact components are manufactured from pressure-resistant and corrosion-resistant materials, suitable for conventional gases as well as certain sour gas environments.

Application Scope

The Portable Hydrostatic Test System is used for on-site pressure testing of valves, fittings, connectors, wellhead components, and other equipment requiring pressure integrity verification.

With a compact and portable design, the system can be rapidly deployed at wellsites, pressure testing areas, assembly sites, maintenance zones, or laboratories, and is suitable for small-scale pressure testing, pressure calibration, sealing verification, and maintenance operations.



- API Spec 6A-2021
- SY/T 5053.1-2000
- SY/T 5127-2002

Technical Parameters

Pressure Rating:	90,000psi	Drive Pressure:	14.5psi ~ 145psi
Test Medium:	Water, Hydraulic Oil, or other specified test media	Equipment Configuration:	Portable enclosure type, small frame-mounted type, or lightweight skid-mounted type
Control Accuracy:	±1%FS		

Functional Features

- The system can generate test pressure through manual or pneumatic operation, making it suitable for different power supply conditions.

Stable

- Adjustable test pressure to meet on-site testing requirements across multiple pressure levels.
- Key wetted components are made of corrosion-resistant materials, suitable for common test media such as water and hydraulic oil.
- Pressure stabilization, pressure holding, and pressure relief functions can be configured as required to suit common test procedures.

Portable

- Compact size and lightweight design allow easy transportation and use in confined spaces.
- Simple operating interface, suitable for on-site verification by maintenance and service personnel.
- Pressure gauges or pressure transmitters can be configured as required for pressure monitoring and recording.

Application Scope

The Portable Gas Tightness Test System is designed for on-site pressurization testing of valves, fittings, connection assemblies, and other equipment requiring pneumatic verification. It is suitable for wellsites, small test areas, process assembly locations, and temporary pressurization scenarios, enabling gas tightness testing, pressure resistance verification, and small-flow pressure make-up operations.

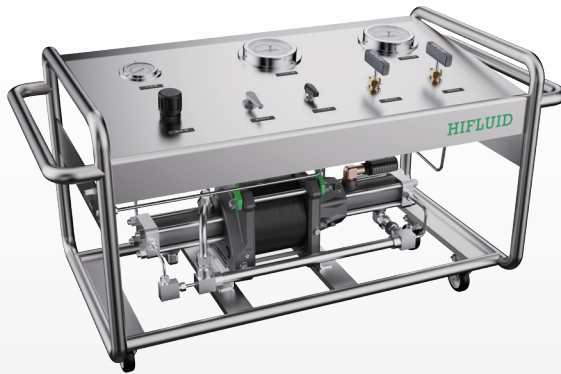

- API Spec 6A
- API Spec 7K
- API Spec 16C
- API Spec 16D
- SY/T 5127
- SY/T 5323

Technical Parameters

Maximum Pressure:	30,000psi	Drive Pressure:	14.5psi ~ 145psi
Test Medium:	Air, Nitrogen, Helium, Natural Gas, and other industrial gases	Equipment Configuration:	Portable enclosure type, small frame-mounted type, or lightweight skid-mounted type
Control Accuracy:	±1%FS		

Functional Features

Explosion-proof

- Pneumatically driven, suitable for operations without electrical power or with explosion-proof requirements.
- Compact structure and lightweight design for easy transportation, deployment, and on-site operation.
- Simple operating interface supporting basic functions such as gas pressurization, pressure holding, and pressure release.

Application Scope

The Hydrostatic Test System is used for pressure resistance testing and strength verification of valves, fittings, blowout preventers, hoses, wellhead components, and other pressure-containing equipment.

The system can be used at wellsites, equipment manufacturing facilities, testing workshops, and maintenance locations. By applying preset pressure to the test object, it enables strength testing, sealing performance testing, and pressure holding verification.



- API Spec 6A
- API Spec 6D
- API Spec 7K
- API Spec 16C
- API Spec 16D
- SY/T 5053.1
- SY/T 5127
- SY/T 5323
- GB/T 22513

Technical Parameters

Maximum Pressure:	60,000psi	Drive Pressure:	14.5psi ~ 145psi
Test Medium:	Water, Hydraulic Oil, or other specified media	Drive Type:	Manual, Pneumatic, Electric
Control Accuracy:	±1%FS	Control Mode:	Manual, PLC, PC
Power Supply:	AC220V/50Hz		

Functional Features

- The system provides stable pressure output, suitable for testing requirements across different pressure levels.
- Stable**
 - Wetted components are manufactured from corrosion-resistant materials and are compatible with water, hydraulic oil, and other test media.
 - Pressure regulation, pressure stabilization, pressure holding, and pressure relief functions can be configured as required to meet various test procedures.
- A split configuration with separate boosting unit and computer-based control improves the operating environment for personnel.
- Intelligent**
 - The system supports stepwise pressurization and depressurization, with configurable pressurization time, pressure holding time, and pressure steps, as well as display and storage of pressure curves.
 - Pressure gauges or pressure transmitters can be configured as required for real-time monitoring of test pressure.

Application Scope

The Gas Tightness Test System is used to perform leak-tightness testing on various equipment, valves, pipelines, fittings, and connectors, ensuring that no gas leakage occurs under specified pressure conditions.

It is widely applicable to oil and gas wellhead equipment, natural gas pipelines, valve manufacturing plants, pipeline pressure testing stations, equipment manufacturers, and maintenance facilities. The system supports multiple gas media and is suitable for high-pressure gas leak testing and sealing performance verification.



- API Spec 6A
- API Spec 6D
- API Spec 7K
- API Spec 16C
- API Spec 16D
- SY/T 5053.1
- SY/T 5127
- SY/T 5323
- GB/T 22513

Technical Parameters

Maximum Pressure:	30,000psi	Drive Pressure:	14.5psi ~ 145psi
Test Medium:	Nitrogen, Air, Helium, and other specified gases	Drive Type:	Manual, Pneumatic, Electric
Control Accuracy:	±1%FS	Control Mode:	Manual, PLC, PC
Power Supply:	AC220V/50Hz		

Functional Features

- The system provides stable pressure output, suitable for testing requirements across different pressure levels.
- Equipped with pressure regulation, pressure stabilization, and pressure relief functions to ensure gas stability and safety during testing.
- High-precision pressure monitoring devices can be configured to monitor pressure variations in real time during testing.
- Pneumatic or electric drive systems are available to suit different operating environments and requirements.
- Key gas-contact components are manufactured from high-pressure-resistant and corrosion-resistant materials, compatible with a wide range of gas media.
- Compact size and integrated structure allow for convenient on-site use and rapid deployment.
- Optional automatic data recording, alarm, and remote monitoring functions enhance testing efficiency and operational safety.

Safe

Portable

Application Scope

The Fatigue Pulse Test System is used to simulate and evaluate the fatigue life of oil and gas wellhead equipment, valves, pipelines, and other pressure-containing components under actual operating conditions.

By applying cyclic pulse pressure, the system simulates pressure fluctuations encountered during long-term operation, thereby verifying equipment durability and reliability.

It is suitable for fatigue testing of valves, wellhead equipment, Christmas trees, pipelines, and similar devices, and is widely used in equipment validation, quality control, and product development within the oil and gas industry.



- API Spec 6A
- API Spec 6D
- API Spec 7K
- API Spec 16C
- API Spec 16D
- SY/T 5053.1
- SY/T 5127
- SY/T 5323
- GB/T 22513

Technical Parameters

Pressure Range:	145psi ~ 30,000psi	Drive Pressure:	14.5psi ~ 145psi
Test Medium:	Hydraulic oil, etc.	Control Mode:	Manual, PLC, PC
Control Accuracy:	±1%FS	Pulse Frequency:	0.1Hz ~ 10Hz
Power Supply:	AC380V/50Hz	Waveform Types:	Square Wave, Triangular Wave, Sine Wave, Water Hammer Wave, etc.

Functional Features

- The system provides stable pressure output, suitable for testing requirements across different pressure levels.
- Equipped with pressure regulation, pressure stabilization, and pressure relief functions to ensure gas stability and safety during testing.
- High-precision pressure monitoring devices can be configured to monitor pressure variations in real time during testing.
- Pneumatic or electric drive systems are available to suit different operating environments and requirements.
- Key gas-contact components are manufactured from high-pressure-resistant and corrosion-resistant materials, compatible with a wide range of gas media.
- Compact size and integrated structure allow for convenient on-site use and rapid deployment.
- Optional automatic data recording, alarm, and remote monitoring functions enhance testing efficiency and operational safety.

Safe

Portable

Testing Systems—Deep-Sea Environment Simulation Test System **HIFLUID**

Application Scope

The Deep-Sea Environment Simulation Test System is designed to simulate high-pressure, low-temperature, and complex operating conditions encountered in deep-sea environments. It is widely used in offshore oil and gas field development, offshore platform equipment testing, and reliability verification of deepwater operation equipment. The system can simulate pressure and low-temperature conditions equivalent to full ocean depth of 12,000 meters, and is suitable for testing various deepwater equipment such as connectors, cables, and instruments.



- API Spec 6A
- API Spec 6D
- API Spec 7K
- API Spec 16C
- API Spec 16D
- SY/T 5053.1
- SY/T 5127
- SY/T 5323
- GB/T 22513

Technical Parameters

Maximum Pressure:	20,000psi	Drive Pressure:	14.5psi ~ 145psi
Test Medium:	Seawater, Oil, Water	Drive Type:	Manual, Pneumatic, Electric
Control Accuracy:	±1%FS	Control Mode:	Manual, PLC, PC
Power Supply:	AC220V/50Hz	Ambient Temperature:	-20°C ~ +80°C

Functional Features

- Capable of simulating high-pressure conditions (up to 20,000 psi) and low-temperature environments (-20°C) encountered in deep-sea applications, providing test conditions that closely replicate actual subsea operations.
- Equipped with high-precision temperature control and pressure control systems to ensure stability and uniformity of temperature and pressure throughout the testing process.
- High-precision sensors and monitoring systems are integrated to record key parameters such as pressure and temperature in real time, ensuring test accuracy and operational safety.
- Supports the simulation of complex conditions such as pressure fluctuations and temperature cycling to evaluate long-term performance of subsea equipment.
- Equipped with overpressure and overtemperature protection devices to ensure safety during testing.
- Optional automatic data recording, alarm, and remote monitoring functions can be configured according to project requirements to enhance testing efficiency and safety.

Safe

Portable

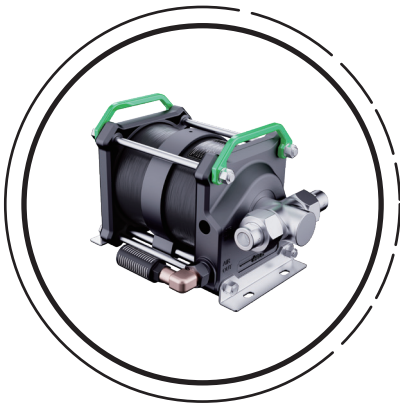

The HiFluid HFLG Series air driven liquid pumps use compressed air as the driving source to pressurize liquid media to the required pressure. Designed for oil, water, and various special liquid media, the pumps can deliver a maximum output pressure of up to 87,000 psi. They play a critical role in numerous applications, particularly in explosion-proof environments with extremely high safety requirements.

Key Features



Oil-Free Compression

No lubricating oil required, eliminating media contamination and maintaining fluid purity.



Intrinsic Safety

No risk of electrical sparks, suitable for flammable and explosive hydrogen environments, compliant with ATEX explosion-proof certification.



Frequent Start-Stop Capability

Unlimited continuous start-stop cycles, especially suitable for intermittent operation.



Automatic Pressure Balancing

Automatically stops upon reaching the target pressure, resulting in zero energy consumption and significant energy savings.



Wide Pressure Range Coverage

Flexible pressure ratio combinations and modular design provide a broad output pressure range to meet both low- and high-pressure requirements.

Typical Applications

● Valve Pressure Calibration, Verification, and Calibration

Provides stable hydraulic power for calibration, verification, and calibration of oilfield components to ensure accuracy.

● Wellhead Pressure Testing

Verifies the sealing integrity of wellhead equipment and casings to ensure operational safety.

● Pressure Resistance and Burst Testing

Supplies high pressure for pressure resistance and burst testing of valves and pipelines.

● Chemical Injection

Precisely injects corrosion inhibitors, demulsifiers, biocides, and other chemicals into oil and gas wells or pipelines to prevent corrosion and improve oil-gas separation efficiency.

● Hydraulic Control

Supplies power for valves and actuators in explosion-proof areas, enabling remote control operations.

● Cleaning and Maintenance

Performs pigging operations on long-distance oil and gas pipelines to remove debris and accumulated liquids, ensuring efficient transportation.

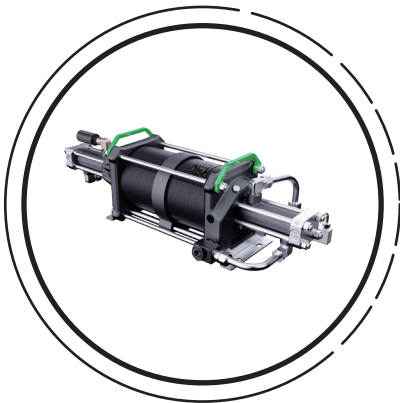

The HiFluid HFG Series air driven gas boosters use compressed air as the driving source to boost process gases to the required pressure. They are widely applied to oil-free compression of various industrial gases such as nitrogen, hydrogen, argon, helium, and methane, with working pressures up to 22,000psi.

Key Features



Oil-Free Compression

No lubricating oil required, eliminating media contamination and maintaining fluid purity.



Frequent Start-Stop Capability

Unlimited continuous start-stop cycles, especially suitable for intermittent operation.



Simple Structure

No electrical power connection required, low maintenance cost, and nearly maintenance-free.



Intrinsic Safety

No risk of electrical sparks, suitable for flammable and explosive hydrogen environments, compliant with ATEX explosion-proof certification.



Automatic Pressure Balancing

Automatically stops upon reaching the target pressure, resulting in zero energy consumption and significant energy savings.



Wide Pressure Range Coverage

Flexible pressure ratio combinations and modular design provide a broad output pressure range to meet both low- and high-pressure requirements.

Typical Applications

Gas Tightness Testing

Supplies high-pressure gas for leak-tightness and pressure resistance testing of wellhead equipment, Christmas trees, and oil & gas pipelines.

Pneumatic Control and Emergency Supply

Provides high-pressure control gas for pneumatic valves and actuators in explosion-proof oilfield areas, ensuring stable equipment operation.

High-Pressure Components—Electrically Driven Gas Boosters **HIFLUID**

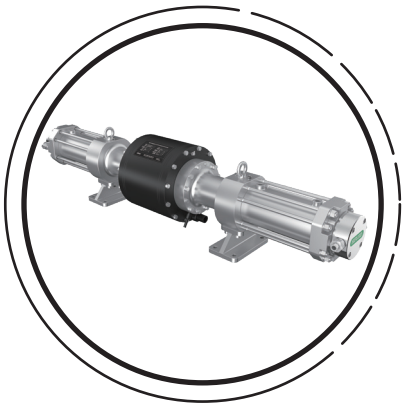

The HiFluid HFEG Series electrically driven gas boosters are designed for oil-free gas compression. Powered by servo-motor precision control, they offer high pressure regulation accuracy, fast response, low energy consumption, and advanced intelligence, making them ideal for high-pressure gas applications with stringent pressure control requirements in the oil and gas industry.

Key Features



Oil-Free Compression

No lubricating oil required, eliminating media contamination and maintaining fluid purity.



Simple Connection

Requires only electrical power and cooling liquid connections to operate.



Simple Structure

Unlimited continuous start-stop cycles, suitable for intermittent operations.



Compact and Efficient

Delivers high flow and high pressure output within a smaller footprint.



Safe and Quiet Operation

Integrated with multiple sensors for self-monitoring, high system integration, communication compatibility, and operating noise below 80dB.



Wide Pressure Range Coverage

Fewer failure points and reduced maintenance requirements compared to hydraulic or diaphragm technologies.

Typical Applications

Gas Tightness Testing

Supplies high-pressure gas for leak-tightness and pressure resistance testing of wellhead equipment, Christmas trees, and oil & gas pipelines.

High-Precision Wellhead and Equipment Testing

Delivers precisely adjustable high-pressure gas for accurate testing of wellheads, valves, and instruments.

Pneumatic Control and Emergency Supply

Provides high-pressure control gas for pneumatic valves and actuators in explosion-proof oilfield areas.

Precision Injection

Precisely controls gas injection pressure to prevent damage to wellbores or reservoirs.

High-Pressure Components—Hydraulically Driven Gas Boosters **HI FLUID**

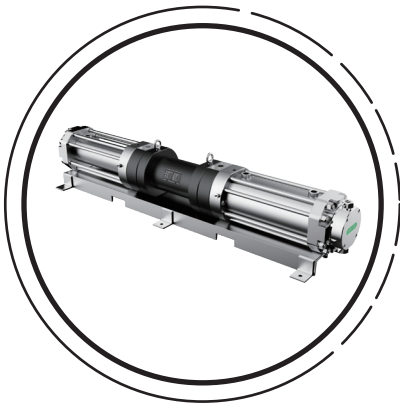

The HiFluid HFHG1 Series hydraulically driven gas boosters use low-pressure hydraulic oil as the driving source to boost process gases to the required pressure. The standard design supports a maximum working pressure of 17,000 psi, with special designs available for higher pressure requirements. These boosters are highly efficient for ultra-high-pressure and large-flow gas applications.

Key Features



Oil-Free Compression

No lubricating oil required, eliminating media contamination and maintaining fluid purity.



Intrinsic Safety

No risk of electrical sparks, suitable for flammable and explosive hydrogen environments, compliant with ATEX explosion-proof certification.



Frequent Start-Stop Capability

Unlimited continuous start-stop cycles, especially suitable for intermittent operation.



Automatic Pressure Balancing

Automatically stops upon reaching the target pressure, resulting in zero energy consumption and significant energy savings.



Wide Pressure Range Coverage

Flexible pressure ratio combinations and modular design provide a broad output pressure range to meet both low- and high-pressure requirements.

Typical Applications

Gas Tightness Testing

Provides high-pressure gas for leak-tightness and pressure resistance testing of large wellhead equipment, Christmas trees, and pipelines.

Gas-Assisted Recovery

Boosts low-pressure gas and injects it into reservoirs for gas flooding to enhance oil recovery; supports high-pressure gas injection for coalbed methane wells to assist desorption and production.

Natural Gas Recovery and Boosting

Compresses associated gas and scattered natural gas to meet transportation pressure requirements, preventing gas flaring and energy loss.

Multiphase Oil & Gas Boosting

Enables integrated boosting and transportation of gas-liquid mixtures (water, oil, gas) from oil and gas wells, reducing backpressure and improving production while avoiding cavitation and liquid hammer risks.

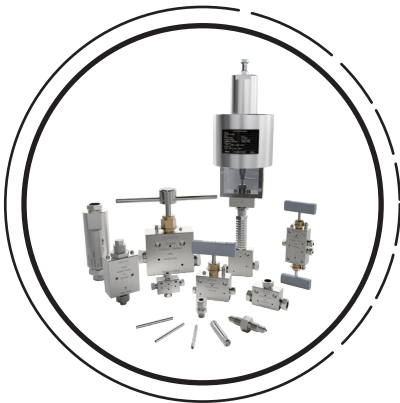

Ultra-high-pressure tubing and valves are critical components for high-pressure energy transmission, flow control, and safety protection. HiFluid provides ultra-high-pressure tubing and valve solutions across multiple pressure ratings, widely applied in oil & gas, energy and chemical processing, high-pressure testing, and processing applications. Featuring high strength, superior sealing, corrosion resistance, and hydrogen embrittlement resistance, these products support working pressures up to 150,000psi and ensure long-term stable operation under extreme conditions.

Key Features



High hydrogen embrittlement & sulfur resistance

Wetted materials exhibit excellent resistance to hydrogen embrittlement and sour service environments.



Intrinsic Safety

No risk of electrical sparks, suitable for flammable and explosive hydrogen environments, compliant with ATEX explosion-proof certification.



Outstanding Sealing Performance

Innovative metal-polymer composite sealing ensures long-term zero leakage even under high-frequency pressure shocks and thermal cycling.



Superior Durability

Proven through millions of pressure cycle fatigue tests, significantly reducing downtime and lifecycle costs.



Customized Services

End-to-end customization from technical consultation and solution design to installation guidance.

Typical Applications

Wellhead Operations

High-pressure needle and choke valves for Christmas trees to control well opening, shut-in, and production rates.

Oil & Gas Production

High-pressure tubing, casing, and connectors for transporting high-pressure fluids while resisting corrosive media.

Refining & Petrochemical

High-pressure valves and fittings for hydrogenation and cracking units under high-temperature, high-pressure, and corrosive conditions.

Storage & Transportation

High-pressure valves for gas storage cylinder banks and storage wells, enabling controlled storage and filling of natural gas, hydrogen, and other gases.

