

Air Driven Gas Boosters

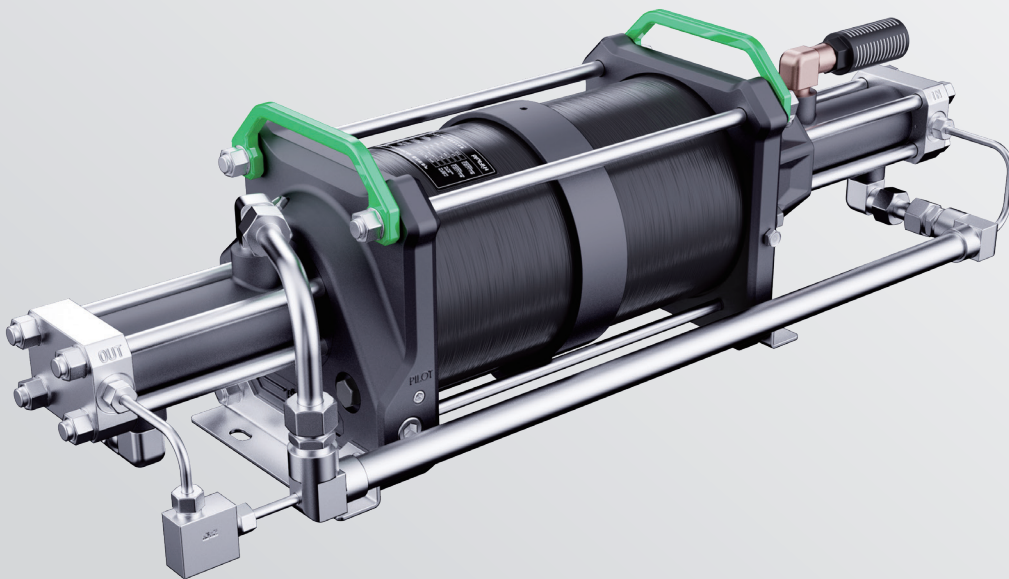



HiFluid, located in Ji'nan, China, national high-tech enterprise, science and technology-based SME, has been focusing on providing safe, stable, intelligent, and customized solutions for advanced ultra-high-pressure fluid applications such as hydrogen compression, high-pressure testing, high-pressure processing (HPP), solid-electrolyte battery production etc. as well as pressure generation unit and control & transfer unit for standard ultra-high-pressure fluid systems since its establishment in 2019. Leveraging its core competencies in design, equipment, and quality assurance, the company is committed to helping customers minimize lifecycle operational costs through energy-saving technologies and extended maintenance intervals.

The company has achieved certifications for ISO 9001 Quality Management System, ISO 14001 Environmental Management System, and ISO 45001 Occupational Health and Safety Management System. We strive to differentiate ourselves from traditional suppliers by embodying the role of consultants and solution providers with our expertise and craftsmanship.

All greatness comes from a brave beginning.

Table of Contents

● — Introduction to HiFluid Gas Boosters	01
● — Applicable Medium Table for HiFluid Gas Boosters	04
● — Single-Drive Single-Acting Gas Boosters	05
● — Single-Drive Double-Acting Gas Boosters	06
● — Single-Drive Two-Stage Gas Boosters	07
● — Double-Drive Single-Acting Gas Boosters	08
● — Double-Drive Double-Acting Gas Boosters	09
● — Double-Drive Two-Stage Gas Boosters	10
● — Selection of HiFluid Gas Boosters	11
● — Installation and Operation Guide for HiFluid Gas Boosters	13
● — Pressure-Flow Rate Curves of HiFluid Gas Boosters	14

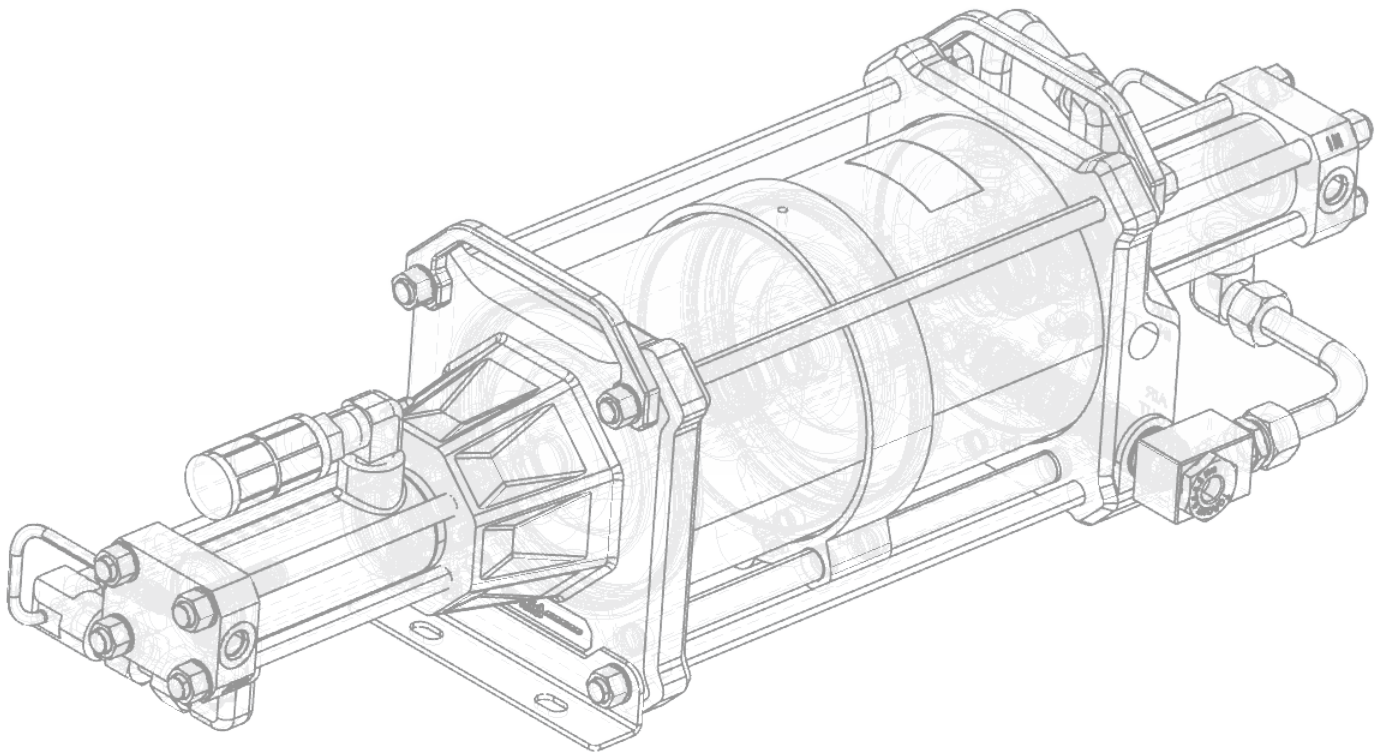

The HiFluid gas booster consists of an air drive section powered by compressed air and a gas section that compresses the medium gas to the required pressure. The working principle is to drive the small area piston through the reciprocating motion of the large area piston to achieve gas boosting. Dynamic seals are used to isolate the two chambers between the air drive section and the gas section, along with a gas discharge outlet, to prevent contamination of the medium gas. Cooling is provided by routing the cold exhausted drive air through an individual jacket surrounding the gas barrel, to achieve a good cooling effect.

Max. output pressure
180MPa

HiFluid gas boosters are widely used for oil-free compression of various industrial gases (such as nitrogen, hydrogen, argon, helium, methane.), with a working pressure of up to 180MPa. They can effectively replace electrically driven boosting equipment and are suitable for applications in various explosion-proof fields.

Key Advantages

- **Flexible Pressure Regulation:** Pressure can be easily adjusted via a manual pressure regulator or pneumatically actuated valve to meet various operational needs.
- **Suitable for Explosion-Proof Environments:** Gas boosters are driven by compressed air and can be used safely in explosion-proof areas, reducing the risk of explosion and fire.
- **Automatic Start-Stop Function:** The gas booster will automatically stop when the preset pressure is reached, and will automatically refill pressure when the pressure drops below the preset level.
- **Wide Range of Medium Compatibility:** The gas booster can be used for conveying and boosting of air and most industrial gases, with high adaptability.
- **Energy-Saving and Environmentally Friendly:** No power consumption or heat generation during pressure holding periods, good for energy and environment.
- **Prevention of Medium Contamination:** The special design between the air drive and gas sections, along with oil-free compression at the gas section, effectively prevents medium contamination.

Typical Applications

Gas boosters are suitable for gas filling, boosting, and conveying in various industrial fields, with a maximum output pressure of up to 180MPa.

- **Gas Leakage Testing:** Provides high-pressure gas for leakage testing of components to detect any leakages.
- **Gas Filling:** Used to fill gas into containers, equipment, or systems to ensure the required pressure is achieved.
- **Gas Recovery:** Used for gas recovery, reuse, or refilling to improve resource utilization efficiency.
- **Gas-Assisted Molding:** Assists in processes such as plastic molding by providing high-pressure gas for better molding results.
- **Gas Compressors:** Used as part of gas compression systems to increase the pressure of specific gases.

Structural Types

HiFluid gas boosters are available in the following six structural types:



Single-Drive Single-Acting

Single-drive piston, each operating cycle achieves one time boost, compact and lightweight.

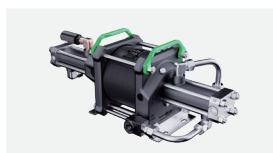

Single-Drive Double-Acting

Single-drive piston, each operating cycle achieves two times boost, offering a larger flow rate compared to single-drive single-acting types under the same pressure ratio.

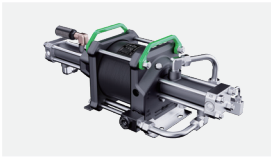

Single-Drive Two-Stage

Single-drive piston, each operating cycle achieves two stages of boosting, capable of boosting lower pressure gases than single-drive double-acting types under the same pressure ratio.

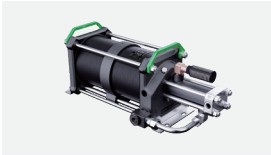

Double-Drive Single-Acting

Double-drive piston, each operating cycle achieves one time boost, offering a larger flow rate compared to single-drive single-acting types under the same pressure ratio, but with higher compressed air consumption.



Double-Drive Double-Acting

Double-drive piston, each operating cycle achieves two times boost, offering a higher flow rate compared to double-drive single-acting types under the same pressure ratio.

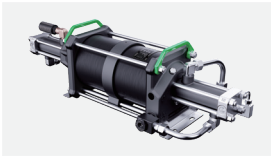

Double-Drive Two-Stage

Double-drive piston, each operating cycle achieves two stages of boosting, capable of boosting lower pressure gases than double-drive double-acting types under the same pressure ratio.

Type Coding

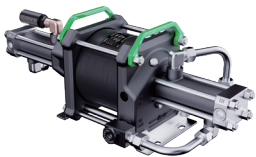
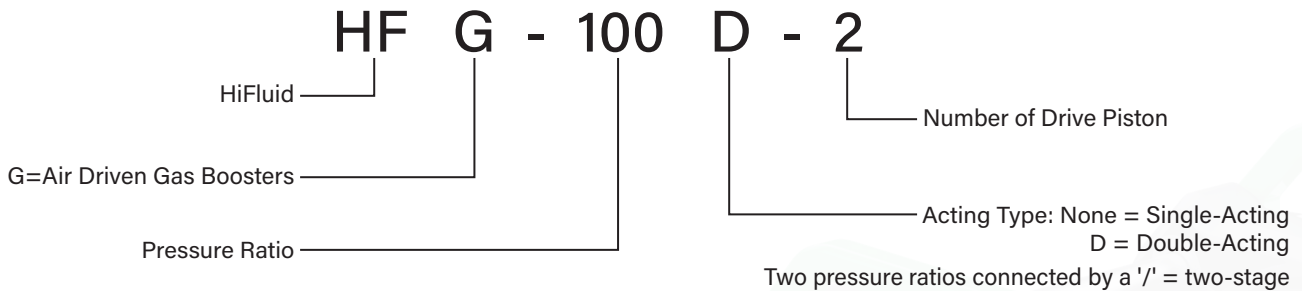

For example: HFG-30D is a gas booster with a pressure ratio of 1:30, double-acting, single-drive.



For example: HFG-15/30-2 is a gas booster with a pressure ratio of 1:15/1:30, two-stage, double-drive.

Core Competencies



01 Digitalization

The company is a pioneer in the industry with the introduction of digital services. Users can scan the QR code on the air driven gas boosters to access relevant electronic documents, making after-sales service more convenient. Moreover, HiFluid plans to further integrate into the global ecosystem through digital marketing, achieving mutual success with stakeholders.

02 Performance and Process

Product development follows the APQP process, with key components optimized through FEA to ensure the optimal matching of product performance and processes.

03 Quality

The production equipments are advanced, and secondary suppliers are managed through process control. Testing equipment is comprehensive, and assembly operations follow standardized processes, ensuring stable and reliable product quality.

04 Sealing

As the core component of the air driven gas boosters, the sealing structure adopts a self-compensating design, ensuring that air pressure acts on the lip. The higher the medium pressure, the greater the contact pressure on the lip, leading to better sealing performance. The elastomer automatically compensates for lip wear, ensuring seal integrity throughout the product's lifecycle. The sealing sliding ring is made from modified PTFE material with added PI, offering excellent wear resistance and a very low friction coefficient (<0.01), allowing for long-term operation without lubrication and preventing stick-slip even after prolonged downtime. The rubber O-ring is made from modified NBR material with extremely low compression set, ensuring sufficient pre-load pressure on the PTFE lip throughout its lifecycle.

05 Verification

The entire product series has undergone type testing verification to ensure it meets theoretical design specifications. In addition, HiFluid actively collaborates with professional third-party testing organizations such as TÜV Rheinland to complete explosion-proof safety assessments, ensuring that product performance meets EU regulations.

06 Design

Industrial beauty is conveyed to customers through sleek and smooth lines, regular geometric shapes, harmonious color schemes, high-quality material selection, exquisite manufacturing craftsmanship, and meticulous attention to detail.

HiFluid Gas Boosters Medium Table

HiFluid gas boosters are suitable for boosting most of commonly available industrial gases (recommended for no moisture content). When selecting the appropriate gas booster, the compatibility between the materials used and the compressed gas should be considered. If there are specific requirements for boosting special gases such as high-purity oxygen or hydrogen, please contact us for assistance. We will provide customized solutions based on the characteristics of the gas.

HiFluid gas boosters are suitable for boosting and conveying the following substances:

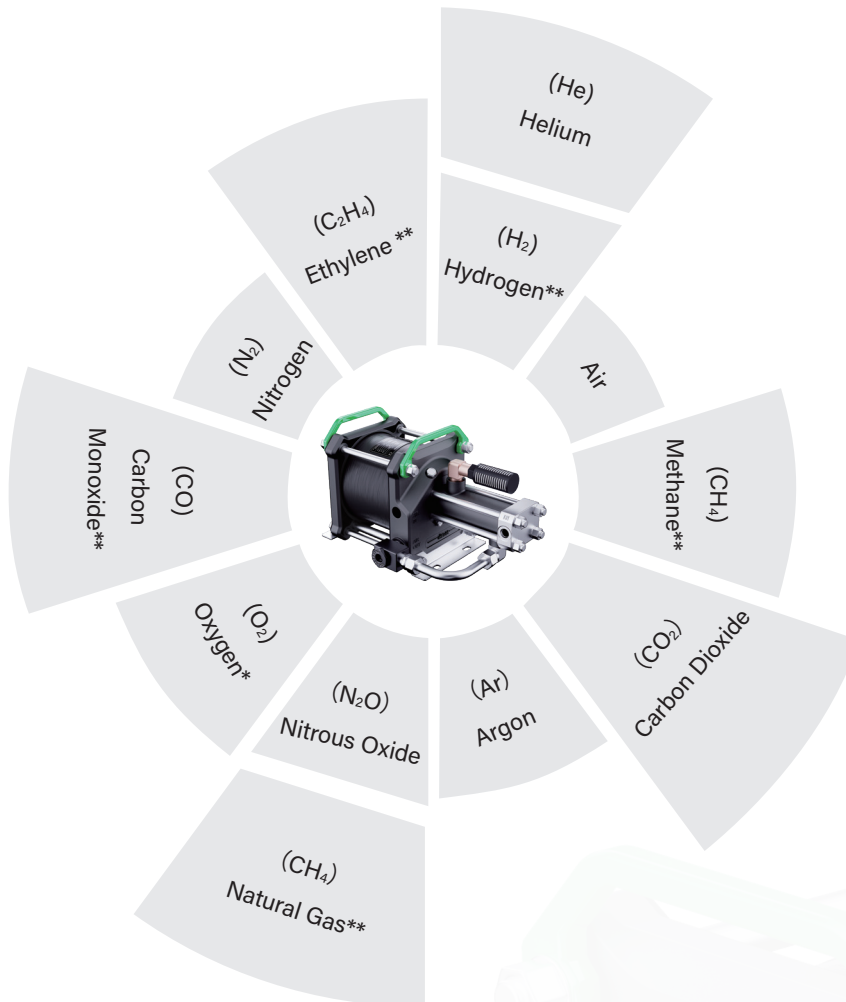

Note:

*The recommended maximum safe working pressure for oxygen (O₂) is 35MPa (5,075 psi).

**For gases marked with two stars, ensure that the gas booster must be operated in a safe and well ventilated area and vent(s) piped to controlled environment.

HiFluid Gas Boosters Series

The single-drive single-acting gas booster achieves one time boost per operating cycle. HiFluid offers six different pressure ratios for applications such as testing or small part filling, where pressure and flow requirements are not high.

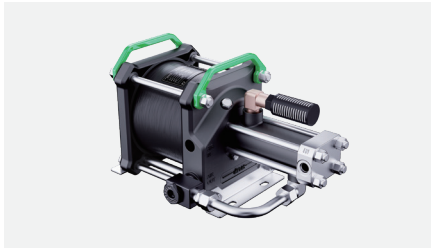

Single-Drive Single-Acting Gas Boosters

- Single-Drive Piston, Single-Acting
- Maximum Output Pressure: 90MPa (13,050psi)
- Suitable for Air Drive Pressure (P_L) at 0.2 to 1MPa (29 to 145psi)
- Actual Output Pressure = Air Drive Pressure * Pressure Ratio

Product Parameters

Type	Pressure Ratio	Displacement /Cycle (ml)	Max. Outlet Pressure		Min. Inlet Pressure		Max. Inlet Pressure		Connection Interface			Dimensions (mm)			Weight (kg)
			MPa	psi	MPa	psi	MPa	psi	Drive Inlet	Medium Inlet	Medium Outlet	A	B	C	
HFG-2	1:2	988	2	290	0	0	2	290	NPT1/2	NPT1/2	NPT1/2	455	255	230	23
HFG-5	1:5	400	5	725	0.2	29	5	725	NPT1/2	NPT3/8	NPT3/8	415	242	230	16
HFG-15	1:15	130	15	2175	0.7	102	15	2175	NPT1/2	H4 (SAE06)	H4 (SAE06)	415	242	230	14
HFG-30	1:30	64	30	4350	1.5	218	30	4350	NPT1/2	H4 (SAE06)	H4 (SAE06)	415	242	230	14
HFG-75	1:75	26	75	10875	3.5	508	75	10875	NPT1/2	H4 (SAE06)	H4	415	242	230	14
HFG-100	1:100	20	90	13050	5	725	90	13050	NPT1/2	H4 (SAE06)	H4	415	242	230	14

Installation Dimensions

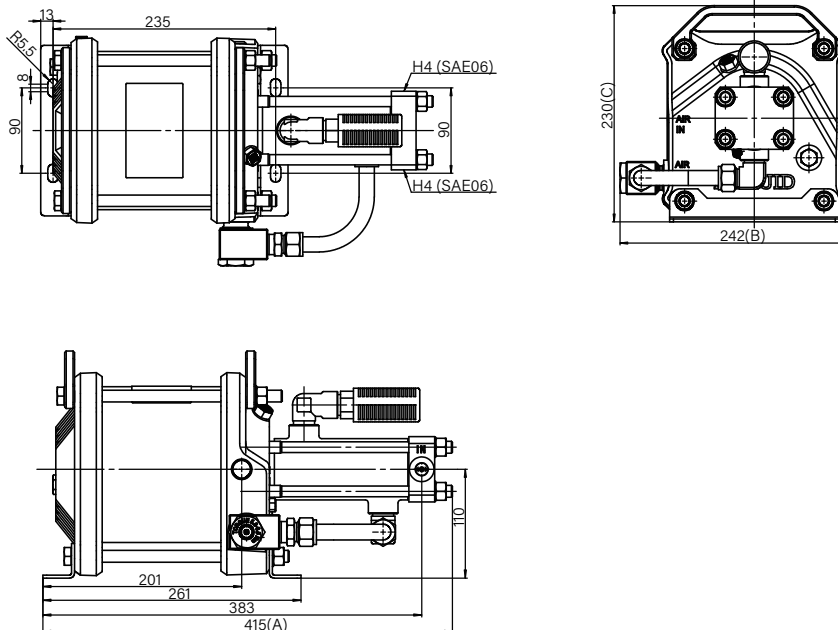

The single-drive double-acting gas booster not only pump larger volume of a single acting booster per cycle, but also require less air drive since the inlet gas pressure is assisting the air drive in each direction. HiFluid offers six different pressure ratios for applications where pressure requirements are low but flow requirements are higher.

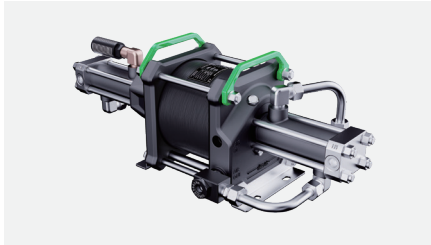

Single-Drive Double-Acting Gas Boosters

- Single-Drive Piston, Double-Acting
- Maximum Output Pressure: 180MPa (26,100psi)
- Suitable for Air Drive Pressure (P_L) at 0.2 to 1MPa (29 to 145psi)
- Actual Output Pressure = Air Drive Pressure * Pressure Ratio + Gas Inlet Pressure

Product Parameters

Type	Pressure Ratio	Displacement /Cycle (ml)	Max. Outlet Pressure		Min. Inlet Pressure		Max. Inlet Pressure		Connection Interface			Dimensions (mm)			Weight (kg)
			MPa	psi	MPa	psi	MPa	psi	Drive Inlet	Medium Inlet	Medium Outlet	A	B	C	
HFG-2D	1:2	1947	4	580	0	0	4	580	NPT1/2	NPT1/2	NPT1/2	455	255	230	23
HFG-5D	1:5	771	10	1450	0.2	29	10	1450	NPT1/2	NPT3/8	NPT3/8	453	242	230	19
HFG-15D	1:15	261	30	4350	0.7	102	30	4350	NPT1/2	H4 (SAE06)	H4 (SAE06)	650	277	230	19
HFG-30D	1:30	128	60	8700	1.5	218	60	8700	NPT1/2	H4 (SAE06)	H4 (SAE06)	650	277	230	20
HFG-75D	1:75	52	150	21750	3.5	508	150	21750	NPT1/2	H4 (SAE06)	H4	650	277	230	20
HFG-100D	1:100	41	180	26100	5	725	180	26100	NPT1/2	H4 (SAE06)	H4	650	277	230	20

Installation Dimensions

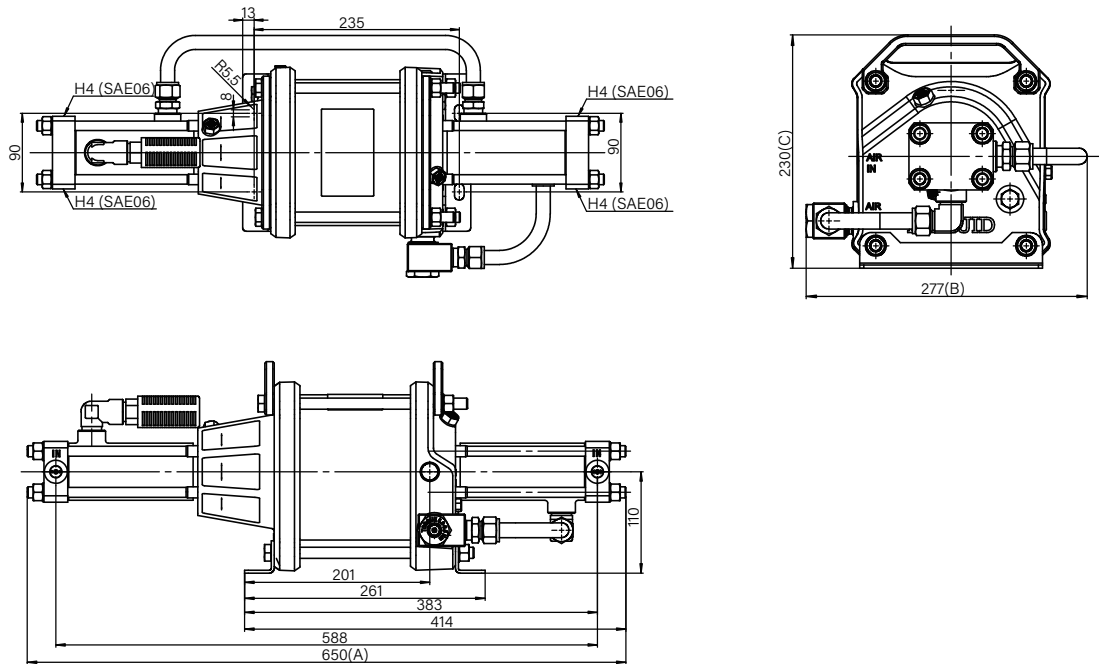

The single-drive two-stage gas booster can boost lower-pressure gases, comparing to single-drive double-acting models under the same pressure ratio. With two different pressure stages for a secondary boost, it could effectively boost the inlet low-pressure medium gas to a higher pressure. HiFluid offers six different pressure ratios to meet applications where the initial pressure of the medium gas is low, but it needs to be boosted to a higher pressure.

Since these models have interconnected gas pistons, they multiply supply pressure during the “interstage” stroke by the area ratio of the two gas pistons. If supply pressure is too high, the booster may have “interstage stall” at an outlet pressure substantially less than that obtainable on the “output” stroke. This limitation does not apply if outlet pressure is less than “the maximum supply” times “the area ratio of the two gas pistons”.

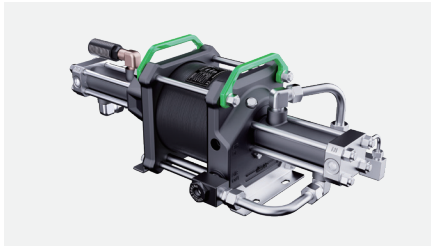

Single-Drive Two-Stage Gas Boosters

- Single-Drive Piston, Two-Stage
- Maximum Output Pressure: 120MPa (17,400psi)
- Suitable for Air Drive Pressure (P_L) at 0.2 to 1MPa (29 to 145psi)
- Actual Output Pressure = Air Drive Pressure * Maximum Pressure Ratio + Area Ratio of Two Gas Pistons (e.g., HFG-5/15, Ratio Is 15/5=3) * Gas Inlet Pressure

Product Parameters

Type	Pressure Ratio	Displacement /Cycle (ml)	Max. Outlet Pressure		Min. Inlet Pressure		Max. Inlet Pressure	Connection Interface			Dimensions (mm)			Weight (kg)
			MPa	psi	MPa	psi		Drive Inlet	Medium Inlet	Medium Outlet	A	B	C	
HFG-5/15	1:5/1:15	400	19.8	2871	0.2	29	2.5P _L	NPT1/2	NPT3/8	H4 (SAE06)	650	298	230	22
HFG-5/30	1:5/1:30	400	33	4785	0.2	29	1.2P _L	NPT1/2	NPT3/8	H4 (SAE06)	650	298	230	22
HFG-15/30	1:15/1:30	130	45	6525	0.7	102	15P _L	NPT1/2	H4 (SAE06)	H4 (SAE06)	650	285	230	20
HFG-15/75	1:15/1:75	130	87.5	12688	0.7	102	5.5P _L	NPT1/2	H4 (SAE06)	H4	650	285	230	20
HFG-30/75	1:30/1:75	64	105	15225	1.5	218	30P _L	NPT1/2	H4 (SAE06)	H4	650	285	230	22
HFG-30/100	1:30/1:100	64	120	17400	1.5	218	20P _L	NPT1/2	H4 (SAE06)	H4	650	285	230	21

Installation Dimensions

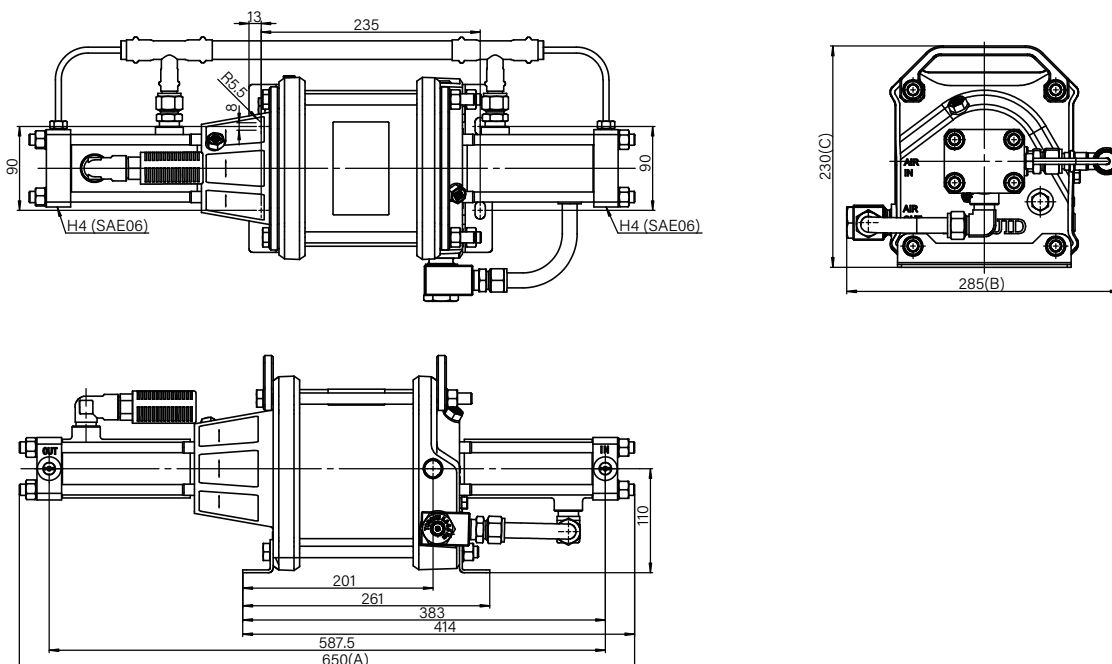

The double-drive single-acting gas booster has a larger flow rate compared to single-drive single-acting models under the same pressure ratio, but also consumes more compressed air. HiFluid offers six different pressure ratios for applications where the medium gas pressure requirement is relatively high.

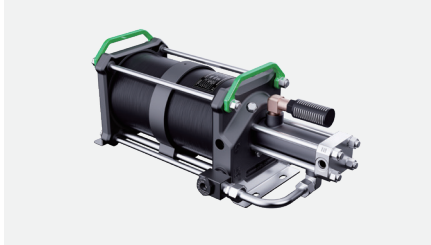

Double-Drive Single-Acting Gas Boosters

- Double-Drive Piston, Single-Acting, output pressure is nearly double that of Single-Drive Piston
- Maximum Output Pressure: 180MPa (26,100psi)
- Suitable for Air Drive Pressure (P_L) at 0.2 to 1MPa (29 to 145psi)
- Actual Output Pressure = Air Drive Pressure * Pressure Ratio

Product Parameters

Type	Pressure Ratio	Displacement /Cycle (ml)	Max. Outlet Pressure		Min. Inlet Pressure		Max. Inlet Pressure		Connection Interface			Dimensions (mm)			Weight (kg)
			MPa	psi	MPa	psi	MPa	psi	Drive Inlet	Medium Inlet	Medium Outlet	A	B	C	
HFG-2-2	1:4	988	4	580	0	0	4	580	NPT1/2	NPT1/2	NPT1/2	615	255	230	29
HFG-5-2	1:10	400	10	1450	0.4	58	10	1450	NPT1/2	NPT3/8	NPT3/8	575	242	230	21
HFG-15-2	1:30	130	30	4350	1	145	30	4350	NPT1/2	H4 (SAE06)	H4 (SAE06)	575	242	230	19
HFG-30-2	1:60	64	60	8700	2	290	60	8700	NPT1/2	H4 (SAE06)	H4 (SAE06)	575	242	230	19
HFG-75-2	1:150	26	150	21750	5	725	150	21750	NPT1/2	H4 (SAE06)	H4	575	242	230	20
HFG-100-2	1:200	20	180	26100	5	725	180	26100	NPT1/2	H4 (SAE06)	H4	575	242	230	20

Installation Dimensions

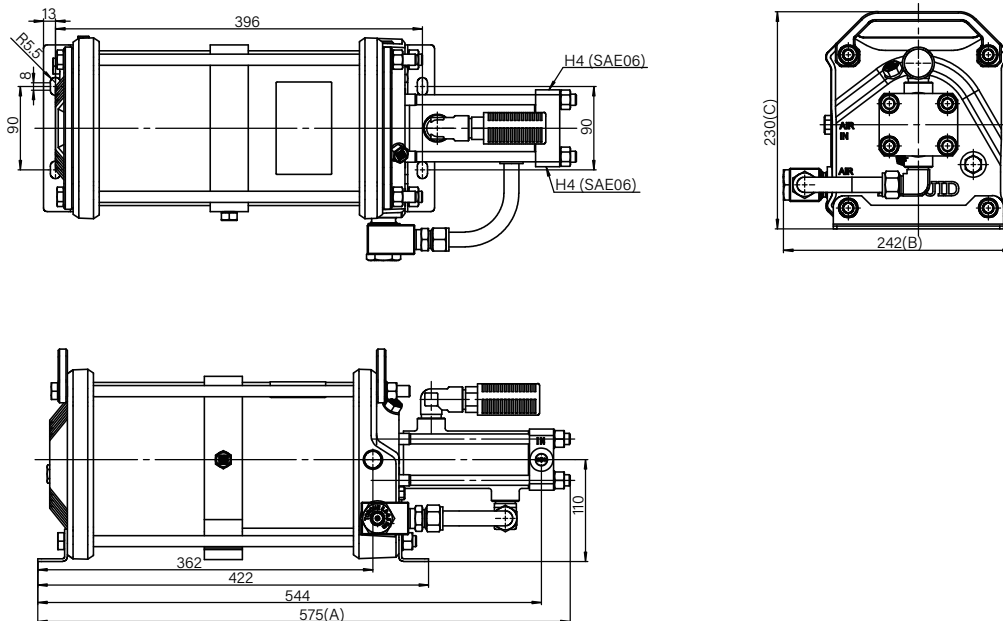

The double-drive double-acting gas booster not only pump larger volume of a single acting booster per cycle, but also require less air drive since the inlet gas pressure is assisting the air drive in each direction. HiFluid offers six different pressure ratios for applications requiring higher flow rates.

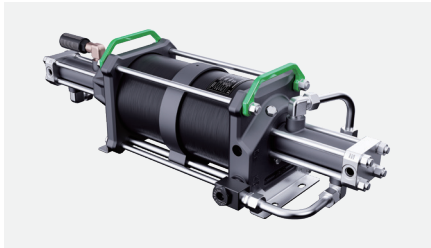

Double-Drive Double-Acting Gas Boosters

- Double-Drive Piston, Double-Acting
- Maximum Output Pressure: 180MPa (26,100psi)
- Suitable for Air Drive Pressure (P_L) at 0.2 to 1MPa (29 to 145psi)
- Actual Output Pressure = Air Drive Pressure * Pressure Ratio + Gas Inlet Pressure

Product Parameters

Type	Pressure Ratio	Displacement /Cycle (ml)	Max. Outlet Pressure		Min. Inlet Pressure		Max. Inlet Pressure		Connection Interface			Dimensions (mm)			Weight (kg)
			MPa	psi	MPa	psi	MPa	psi	Drive Inlet	Medium Inlet	Medium Outlet	A	B	C	
HFG-2D-2	1:4	1947	4	580	0	0	4	580	NPT1/2	NPT1/2	NPT1/2	615	255	230	29
HFG-5D-2	1:10	771	10	1450	0.5	73	10	1450	NPT1/2	NPT3/8	NPT3/8	615	242	230	24
HFG-15D-2	1:30	261	30	4350	0.7	102	30	4350	NPT1/2	H4 (SAE06)	H4 (SAE06)	810	277	230	24
HFG-30D-2	1:60	128	60	8700	2	290	60	8700	NPT1/2	H4 (SAE06)	H4 (SAE06)	810	277	230	25
HFG-75D-2	1:150	52	150	21750	4.5	653	150	21750	NPT1/2	H4 (SAE06)	H4	810	277	230	26
HFG-100D-2	1:200	41	180	26100	5	725	180	26100	NPT1/2	H4 (SAE06)	H4	810	275	230	26

Installation Dimensions

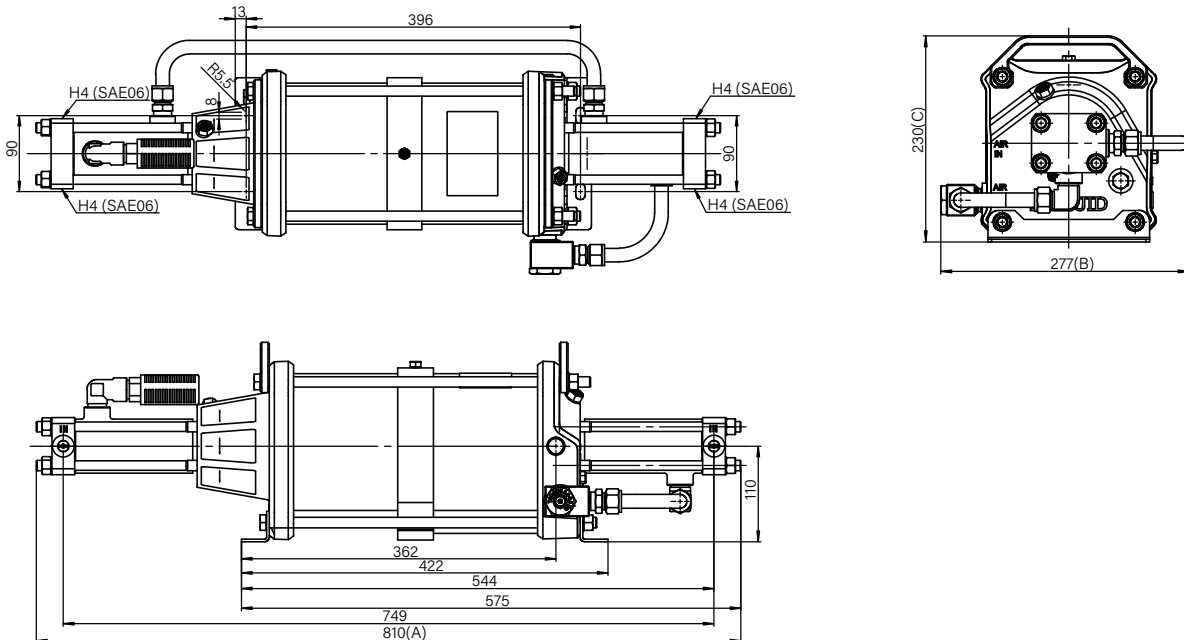

The double-drive two-stage gas booster can boost lower-pressure gases, comparing to double-drive double-acting models under the same pressure ratio. With two different pressure stages for a secondary boost, it could effectively boost the inlet low-pressure medium gas to a higher pressure. HiFluid offers six different pressure ratios to meet applications where the initial pressure of the medium gas is low, but it needs to be boosted to a higher pressure.

Since these models have interconnected gas pistons, they multiply supply pressure during the “interstage” stroke by the area ratio of the two gas pistons. If supply pressure is too high, the booster may have “interstage stall” at an outlet pressure substantially less than that obtainable on the “output” stroke. This limitation does not apply if outlet pressure is less than “the maximum supply” times “the area ratio of the two gas pistons”.

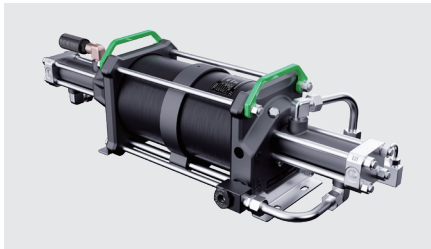

Double-Drive Two-Stage Gas Boosters

- Double-Drive Piston, Two-Stage
- Maximum Output Pressure: 180MPa (26,100psi)
- Suitable for Air Drive Pressure (P_L) at 0.2 to 1MPa (29 to 145psi)
- Actual Output Pressure = Air Drive Pressure * Maximum Pressure Ratio + Area Ratio of Two Gas Pistons (e.g., HFG-5/15-2, Ratio Is $15/5=3$) * Gas Inlet Pressure

Product Parameters

Type	Pressure Ratio	Displacement /Cycle (ml)	Max. Outlet Pressure		Min. Inlet Pressure		Max. Inlet Pressure	Connection Interface			Dimensions (mm)			Weight (kg)
			MPa	psi	MPa	psi		Drive Inlet	Medium Inlet	Medium Outlet	A	B	C	
HFG-5/15-2	1:10/1:30	400	30	4350	0.2	29	5P _L	NPT1/2	NPT3/8	H4 (SAE06)	810	298	230	27
HFG-5/30-2	1:10/1:60	400	60	8700	0.2	29	2.4P _L	NPT1/2	NPT3/8	H4 (SAE06)	810	298	230	28
HFG-15/30-2	1:30/1:60	130	60	8700	0.7	102	30P _L	NPT1/2	H4 (SAE06)	H4 (SAE06)	810	285	230	25
HFG-15/75-2	1:30/1:150	130	150	21750	0.7	102	11P _L	NPT1/2	H4 (SAE06)	H4	810	285	230	25
HFG-30/75-2	1:60/1:150	64	150	21750	1.5	218	60P _L	NPT1/2	H4 (SAE06)	H4	810	285	230	26
HFG-30/100-2	1:60/1:200	64	180	26100	1.5	218	40P _L	NPT1/2	H4 (SAE06)	H4	810	285	230	26

Installation Dimensions

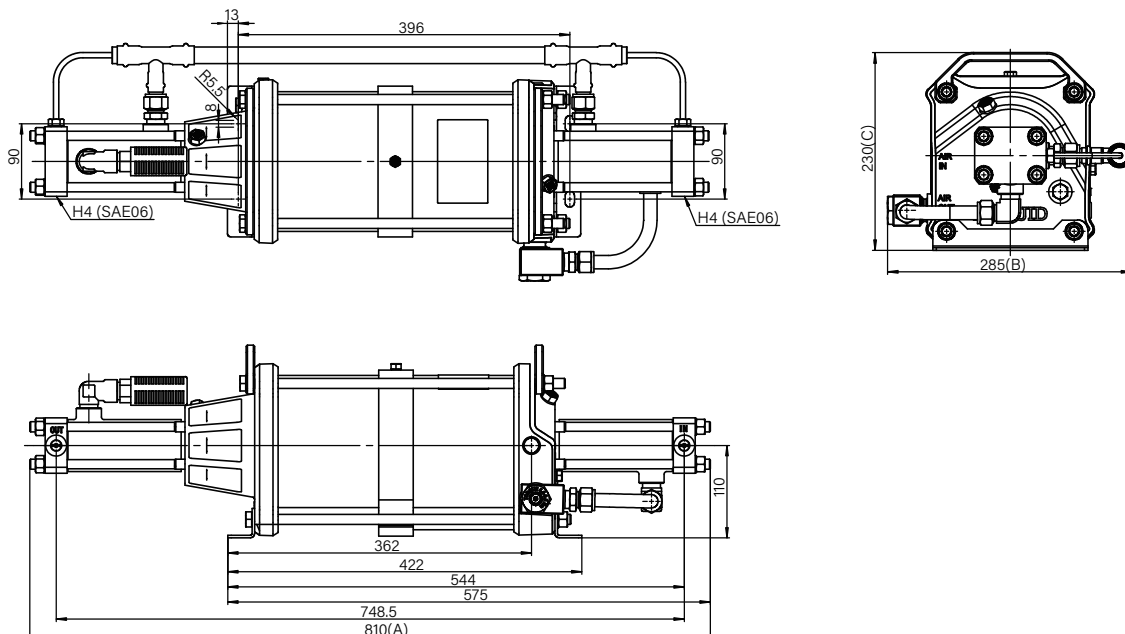

Selection of HiFluid Gas Boosters

Based on the different flow and pressure requirements of the customer’s application scenarios, HiFluid gas boosters are classified into 6 types, with the main differences as follows:

Series	Medium Inlet Pressure	Maximum Outlet Pressure	Maximum Output Flow Rate
Single-Drive Single-Acting	★★★	★★★	★★★★★
Single-Drive Double-Acting	★★★	★★★★★	★★★★★
Single-Drive Two-Stage	★★	★★★★★	★★★★★
Double-Drive Single-Acting	★★★★★	★★★★★	★★
Double-Drive Double-Acting	★★★★★	★★★★★	★★★
Double-Drive Two-Stage	★★	★★★★★	★★★★★

When selecting the appropriate gas booster, the required output flow and pressure should be determined based on the application scenario. The performance of the gas booster is affected by the air drive pressure, the medium gas inlet pressure, and the pressure ratio. Additionally, the way of gas supply is also an important consideration. For example, if a gas cylinder is used to supply gas for testing components, the inlet pressure, outlet pressure, and outlet flow will decrease as the cylinder pressure drops.

To obtain professional selection advice, it is recommended to contact HiFluid's technical experts or sales team. If your technical requirements are clear, such as providing stable inlet pressure and requiring constant outlet flow, please refer to the performance parameters in this manual for selection. When making a choice based on actual application needs, other factors such as installation space should also be considered.

Key points for selecting a gas booster are as follows:



- ① Medium Outlet Pressure P_B : Required outlet pressure of the medium gas.
- ② Air Drive Pressure P_L : The compressed air pressure supplied to the gas booster.
- ③ Gas Inlet Pressure P_A : The inlet pressure of the medium gas to be boosted.
- ④ Flow Rate Q : The required output flow of the medium gas.

⑤ Boosting Medium: The properties of the medium determine the sealing material. If special mediums are used, please consult HiFluid sales.

⑥ Medium Temperature: Extremely high or low medium temperatures can shorten the life of the seals. We recommend to have the temperature range from -10°C to 100°C. Please consult HiFluid sales if outside this range.

⑦ Ambient Temperature: If used in extremely high or low ambient temperatures, the air driven gas boosters may not function properly. We recommend to have the ambient temperature from 0°C to 60°C. Please consult HiFluid sales if outside this range.

⑧ Drive Air Quality: We recommend that the air quality at least meets ISO 8573-1 Class 4 requirements.

To maximize the lifespan of the seals, it is recommended to keep the cycle rate of the gas booster below 60 cycles per minute.

Gas Booster Selection Example

A customer requires a gas booster with the following specific operating conditions:

Medium	Medium Inlet Pressure P_A	Medium Outlet Pressure P_B	Flow Rate Q	Air Drive Pressure P_L	Medium Temperature	Ambient Temperature
Argon(Ar)	0.8MPa	35MPa	5 L_N /min	0.7MPa	20°C	25°C

Based on the parameters provided by the customer, the boosting medium is identified as the inert gas "Argon"; the medium temperature and ambient temperature are within the normal range, allowing for further selection.

1. Medium

- Argon is an inert gas, all HiFluid gas booster types are suitable for Argon without any restrictions. If the gas booster is used in open and ventilated areas, the environmental cleanliness must be considered.

2. Minimum Pressure Ratio

- Minimum Pressure Ratio = Medium Outlet Pressure P_B / Air Drive Pressure P_L
= 35MPa / 0.7MPa = 50

- Select a gas booster with a pressure ratio greater than and close to 1:50, specific models are as follows:

HFG-75	HFG-75D	HFG-15/75	HFG-30/75	HFG-30-2	HFG-30D-2	HFG-5/30-2	HFG-15/30-2
--------	---------	-----------	-----------	----------	-----------	------------	-------------

3. Minimum Gas Inlet Pressure

- According to the HiFluid website or the manual's performance parameters for each gas booster type, select a gas booster with a minimum inlet pressure less than or equal to the actual inlet pressure. In this case, the medium gas inlet pressure $P_A=0.8$ MPa, so a gas booster with a minimum inlet pressure ≤ 0.8 MPa should be selected:

HFG-15/75	HFG-5/30-2	HFG-15/30-2
-----------	------------	-------------

4. Compression Ratio

- Compression ratio ϵ = Gas Outlet Pressure P_B / Gas Inlet Pressure P_A
= 35MPa / 0.8MPa = 43.75

- Therefore, a gas booster with a maximum compression ratio $\epsilon \geq 1:43.75$ should be selected.

Based on the performance of the gas boosters, ϵ is calculated as follows:

- HFG-15/75: $700/7=100$
- HFG-5/30-2: $480/2=240$
- HFG-15/30-2: $480/7=68.57$

- From the calculations, the above gas boosters all meet the requirement of a compression ratio $\epsilon > 1:43.75$.

5. Flow Rate

- Please refer to the pressure-flow curve chart and select a gas booster from the above models that meets the flow rate requirement of 5 L_N /min.

6. Confirm the Gas Booster Model

Note: The minimum pressure ratio is obtained by dividing the outlet pressure P_B by the air drive pressure P_L , which helps minimize the selection range P_B .

- The compression ratio ϵ is also an important criterion, it is the ratio of the gas outlet pressure to the inlet pressure. The compression ratio is a key indicator of the temperature rise during the compression process. As the compression ratio increases, the temperature generated during gas compression also rises. When using a gas booster, it is essential to ensure that the compression ratio does not exceed its maximum tolerable range.

01 Preparation Work

Check and ensure the gas booster model, parameters match the actual application requirements. Confirm that the booster and its components are undamaged during transport.

02 Select Installation Location

Choose a flat surface capable of bearing the booster's weight. Ensure the environment is dry and well-ventilated, with enough space for operation. Avoid extreme temperatures, humidity, or corrosive gases.

03 Installation Foundation

Fix the the gas booster to the equipment using appropriate bolts and nuts to minimize vibration and movement. In general, the air inlet is positioned on the top, and the medium inlets/outlets at the bottom (vertical installation). This setup helps protect the seals, extending the booster's lifespan.

04 Connect the Compressed Air

Ensure the compressed air is clean. Use air filters, pressure regulators, lubricators, and high-quality piping and fittings. The air pressure should meet the booster requirements (usually 0.2-1MPa), and air quality should meet at least ISO 8573-1 Class 4.

05 Connect the Gas Pipeline

Select corrosion-resistant, pressure-resistant piping material based on the medium properties and ensure a secure connection of the medium inlet pipe. It is recommended that the pipe size connected to the booster is larger than the booster interface size to ensure smooth medium flow and reduce energy loss.

06 Start

Open the compressed air valve and gradually increase the air pressure until the booster starts operating. Observe whether the start is smooth, without abnormal vibrations or noise.

07 Observe

Monitor the medium flow and pressure. If any abnormalities are observed, immediately stop the booster and inspect.

08 Adjustment

Adjust the air pressure as needed to achieve different output pressures and flow rates.

09 Stop

Gradually reduce the air pressure and close the air valve. For long periods of inactivity, drain any remaining medium from the booster to prevent corrosion and scaling.

Single-Drive Single-Acting

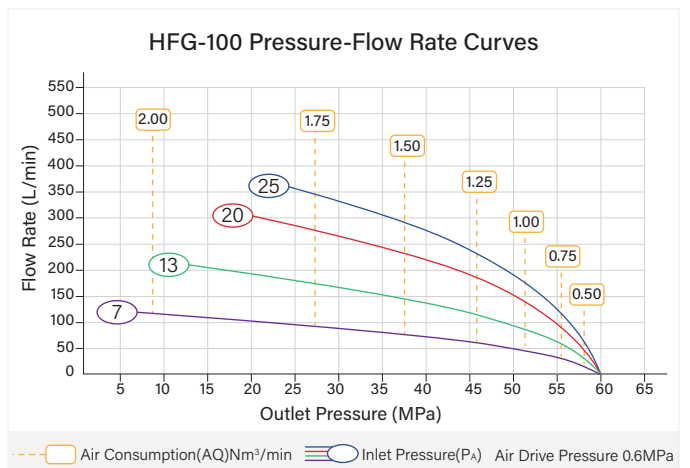
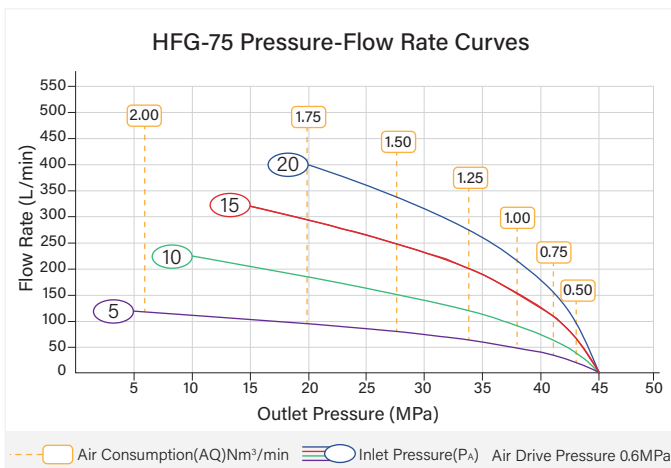
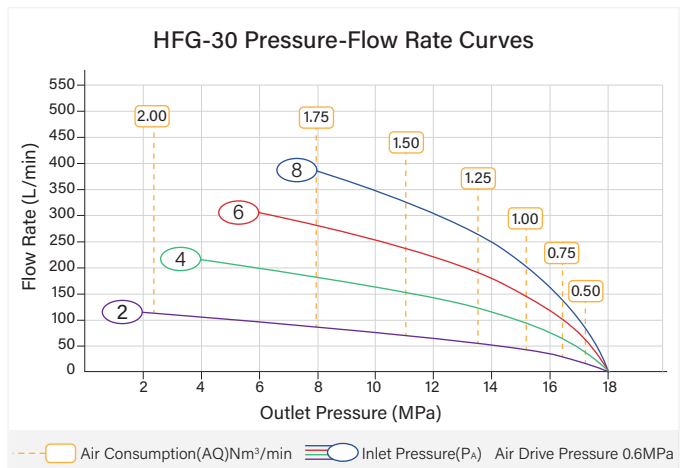
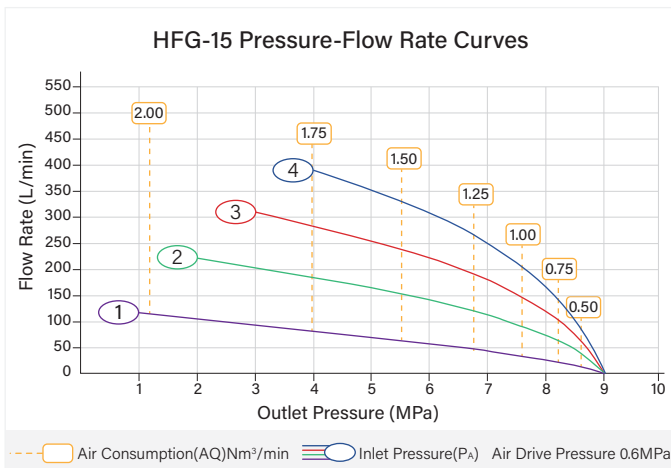
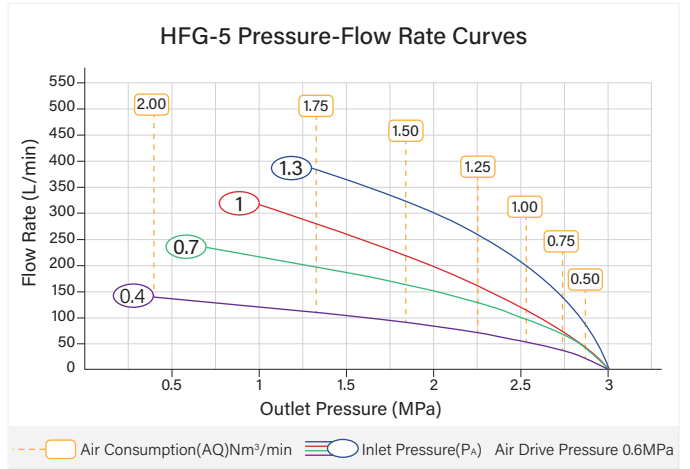
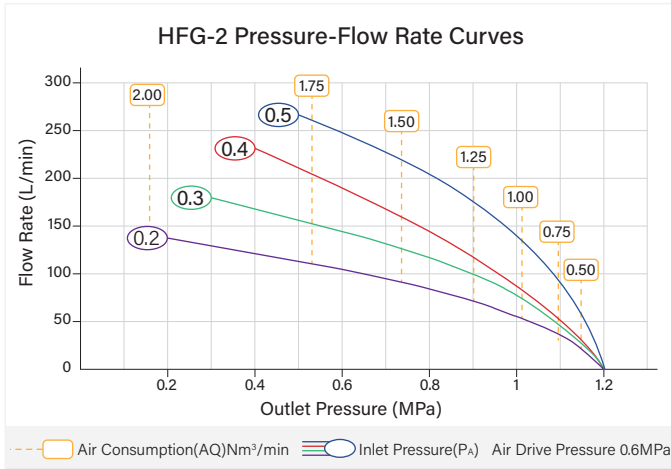

Single-Drive Double-Acting

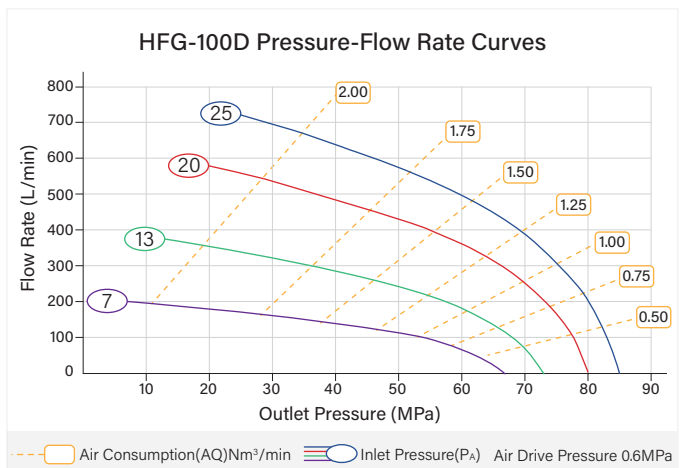
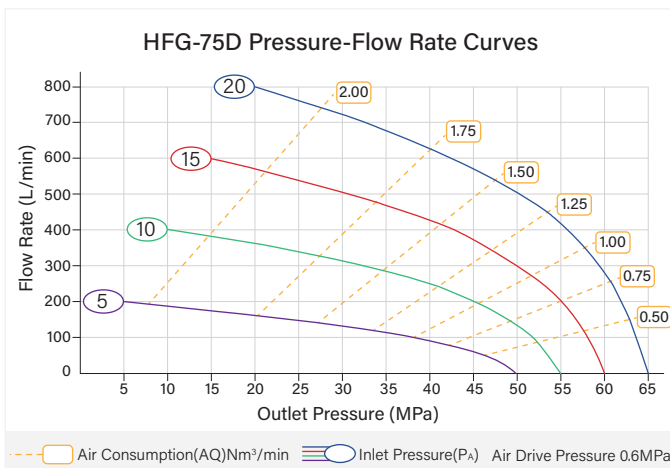
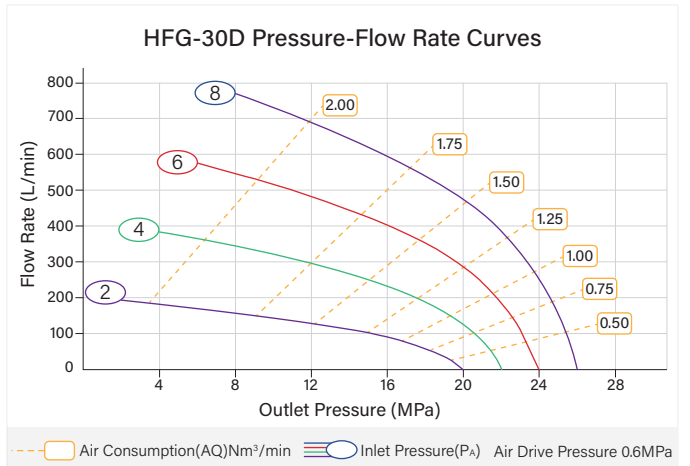
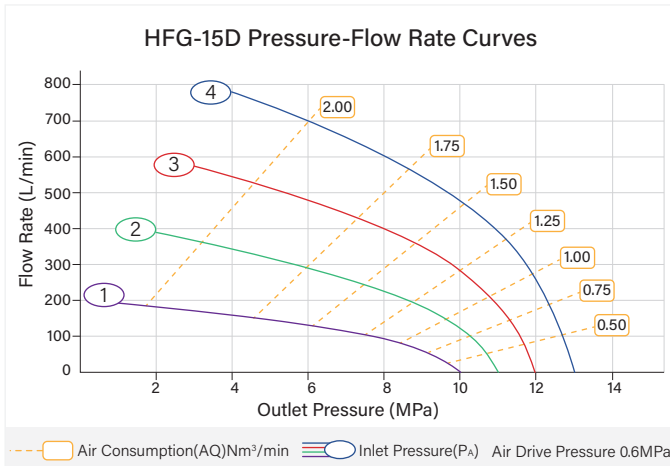
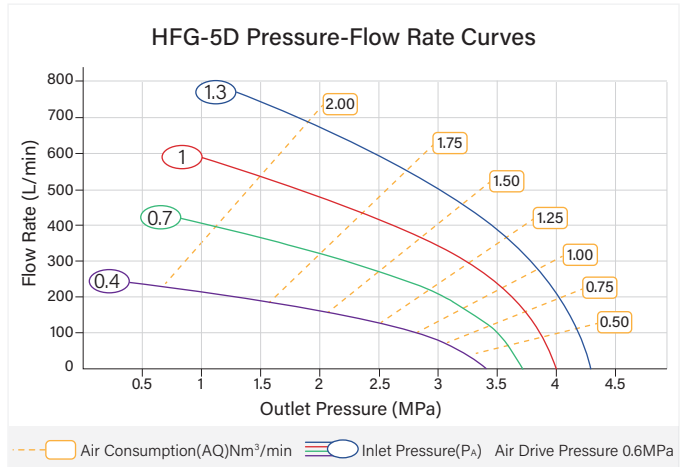
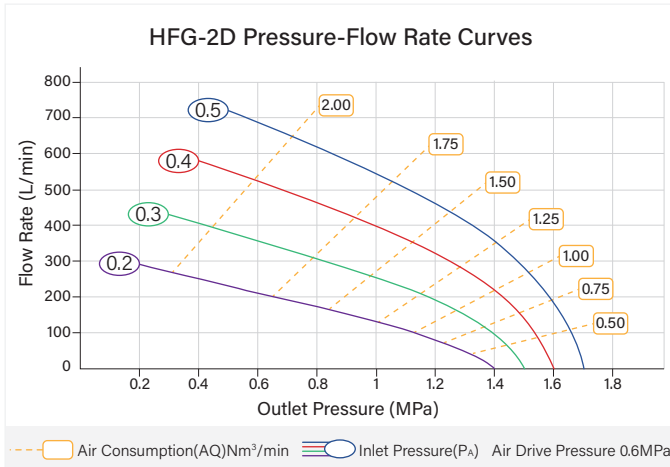

Single-Drive Two-Stage

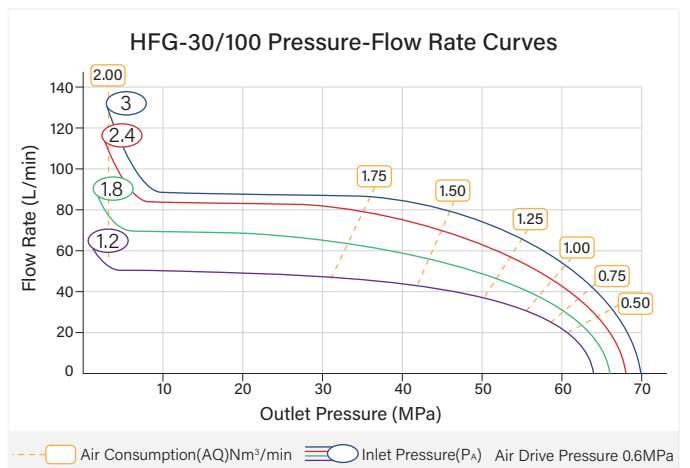
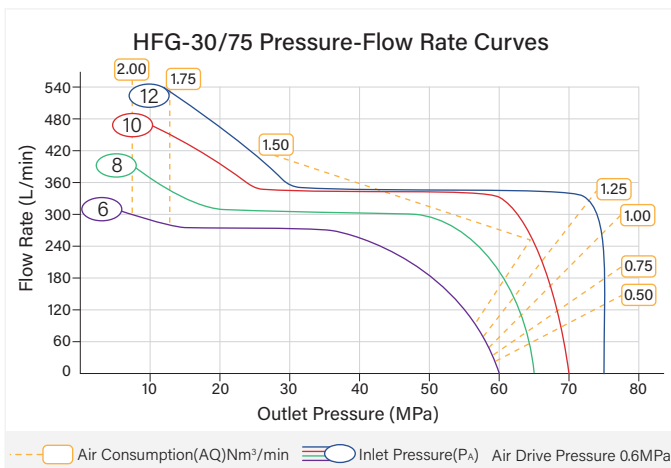
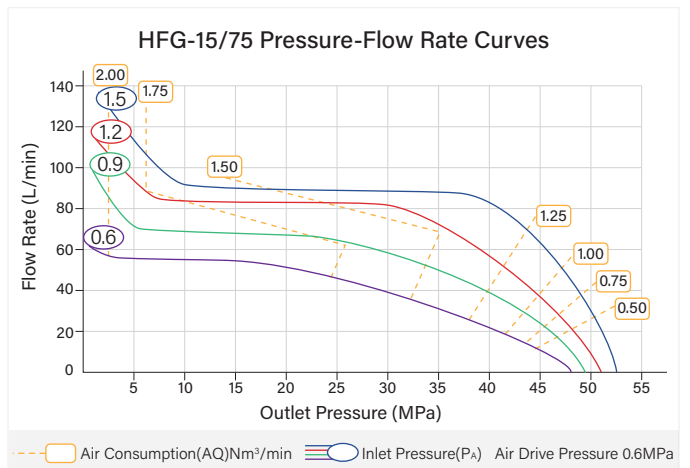
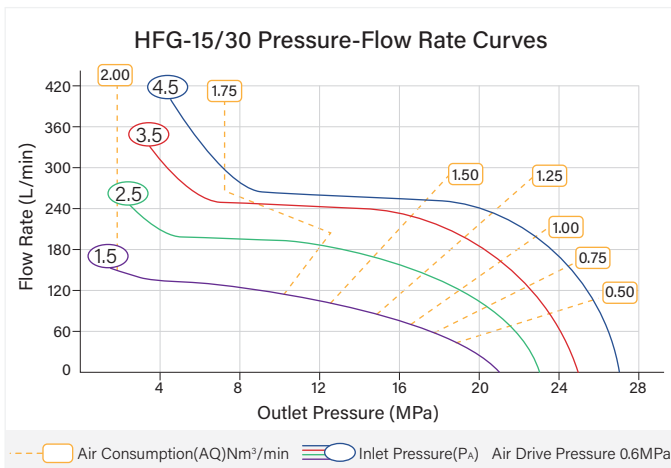
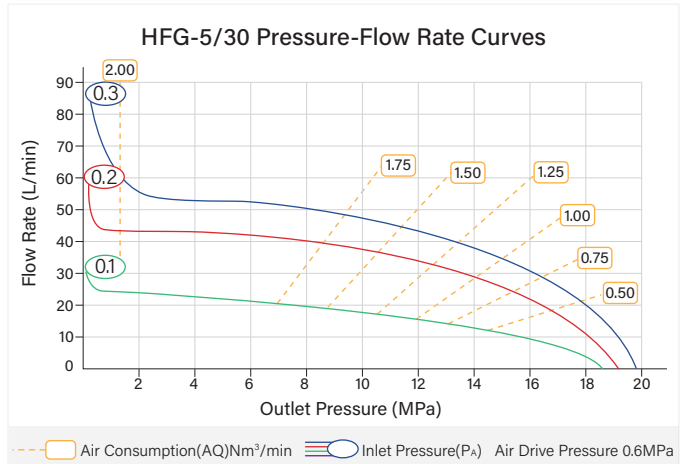
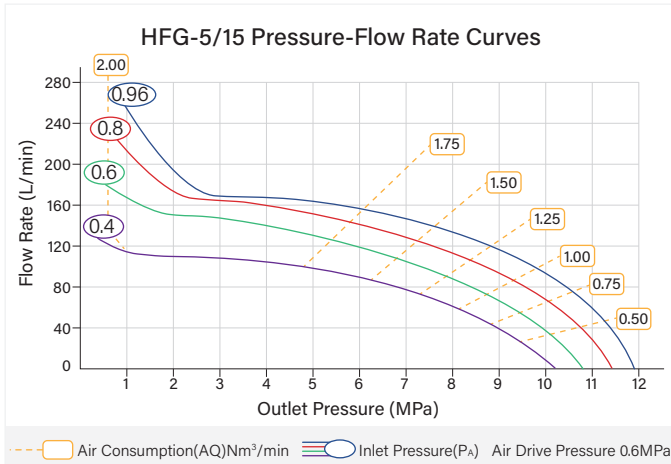

Double-Drive Single-Acting

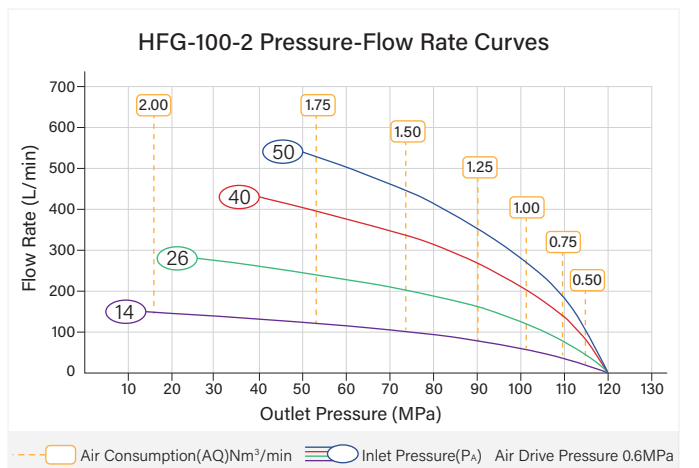
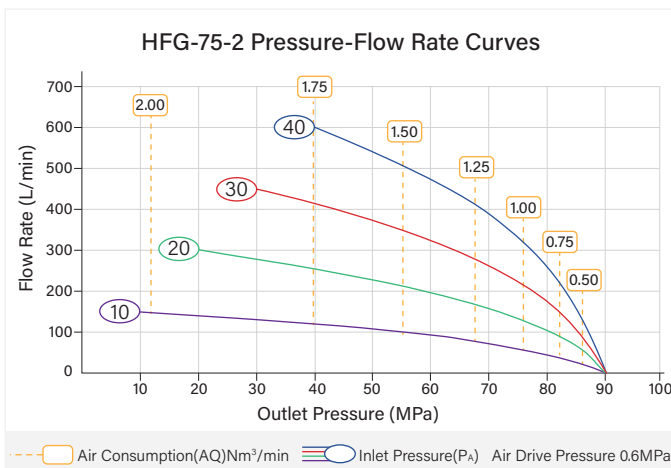
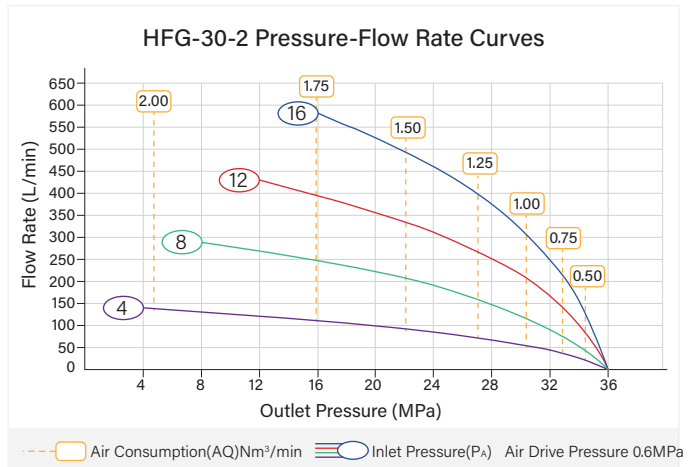
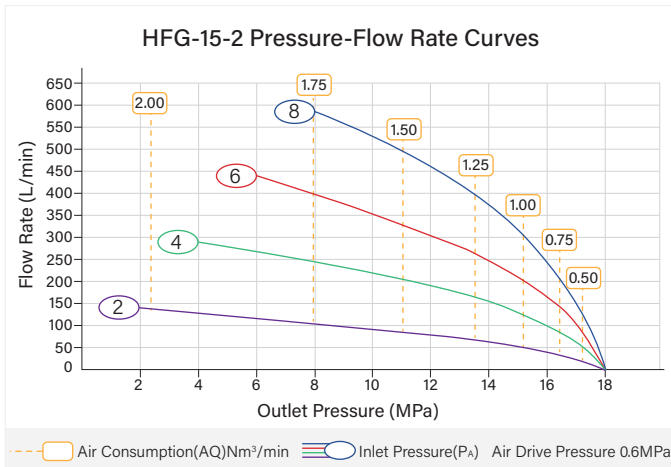
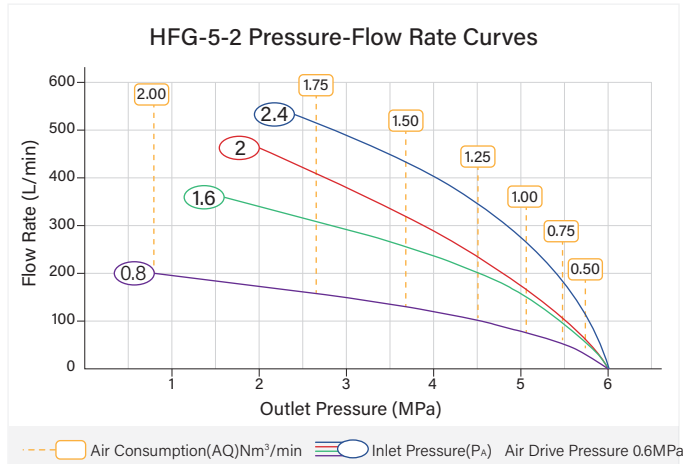
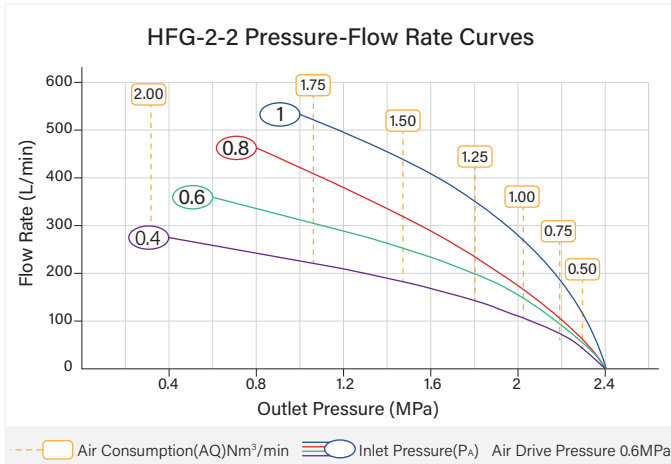

Double-Drive Double-Acting

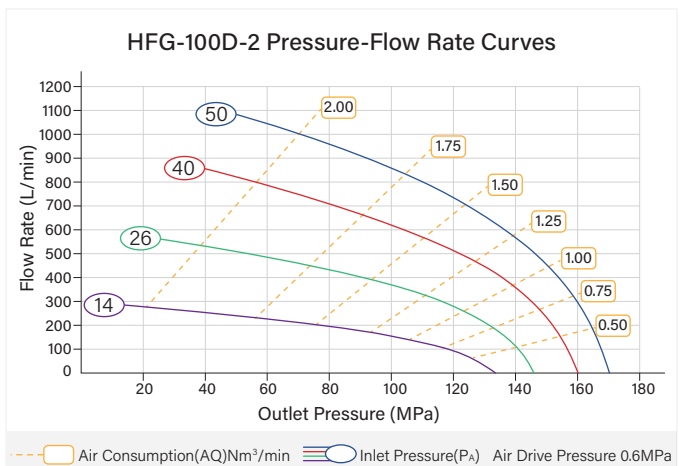
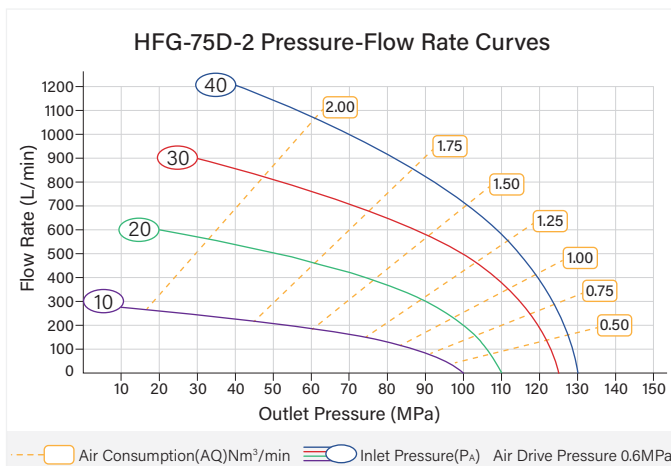
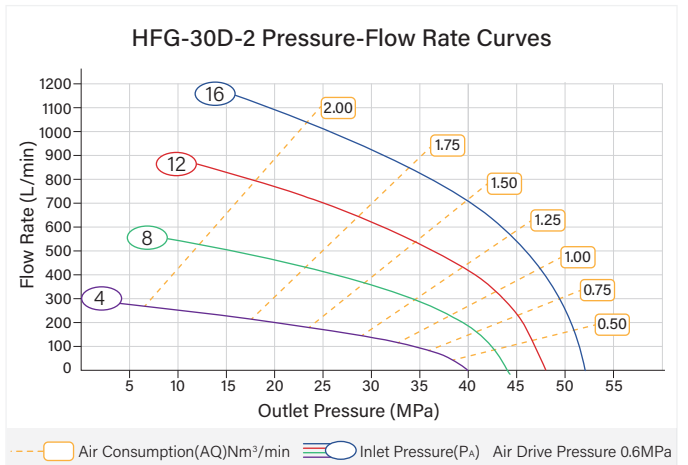
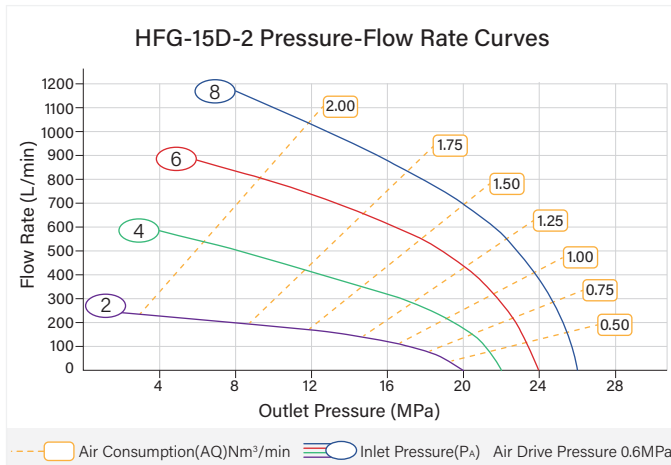
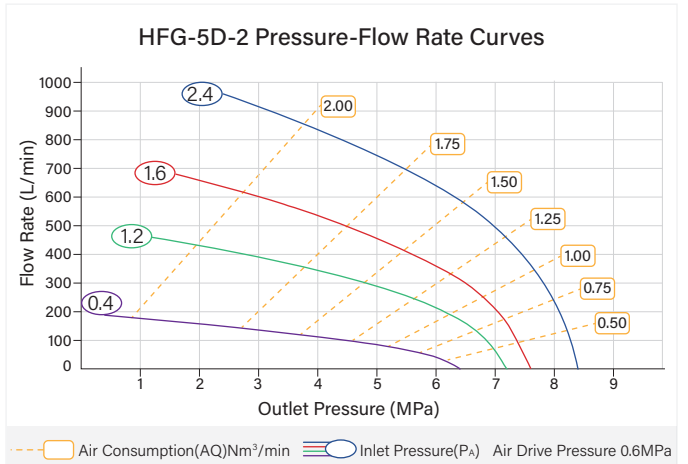
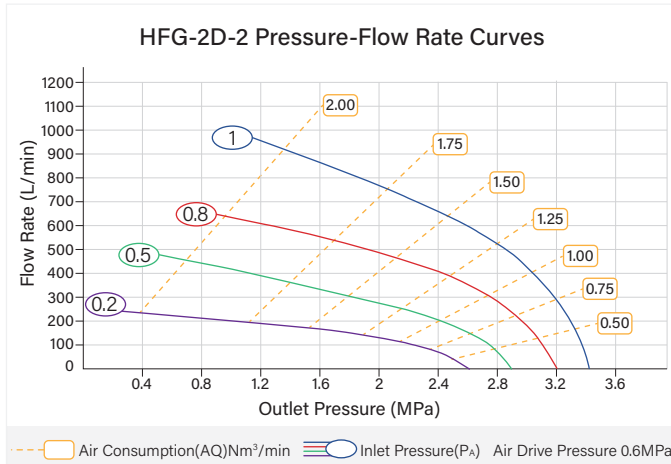

Double-Drive Two-Stage

